

UK CYLINDERS



YOUR HOT WATER SPECIALISTS

Indirect Heat Pump Cylinders

NEW INSTRUCTION - USE OF THERMAL PASTE - PAGE 7

INSTALLATION MANUAL V1 JAN 2026

INDIRECT UNVENTED HOT WATER STORAGE CYLINDER
WITH **EXTERNAL** EXPANSION VESSEL

Heat Pump - Indirect Single Coil, Indirect Solar Twin Coil, Horizontal and
Combined Indirect Coil Cylinder and Buffer Store

IMPORTANT

This range of unvented water storage cylinders should only be installed as per these instructions by a competent & certified heating installer. By installing this product you agree to be bound by the purchasing and warranty terms and conditions found in this manual and on our website.

Safe Disposal and WEEE Declaration

This cylinder is manufactured from and supplied with a variety of components made from recyclable materials. At the end of its working life, a hot water cylinder should be disposed of at a Local Authority Recycling Centre.

The Waste Electrical and Electronic Equipment (WEEE) directive makes use of the wheelie bin symbol, which indicates that this product must not be disposed of with regular household waste. Instead all products with this symbol must be disposed of at a designated point for the recycling of waste electrical equipment.

For more information about where you can drop off your WEEE please contact your household waste disposal service or the point of purchase for any of your electrical goods.



INTRODUCTION

This UK manufactured product is made from Duplex stainless steel, providing durability and long-lasting resistance against corrosion. It is highly insulated with environmentally friendly foam, and enclosed in a rust resistant outer steel case.

The Indirect is an indirectly heated unvented hot water storage cylinder as defined under the current ErP Directive and available in eight sizes from 60-300litres.

The cylinder is approved to comply with G3 Building Regulations and the United Kingdom Water Supply (Water Fittings) Regulations / Scottish Water Byelaws.

This Indirect cylinder comes supplied with all necessary safety & control devices needed to connect to the water mains. If for any reason you suspect this may not be the case, please contact us (see back page).

Please ensure that you have understood this manual before starting the installation, and leave this guide with the end user once the installation is complete.

For information on potential Warranty Exclusions – please see the appendix of this installation manual.

BENCHMARK

The Benchmark scheme places responsibilities on both manufacturers and installers. The purpose is to ensure that customers are provided with the correct equipment for their needs, that it is installed, commissioned and serviced in accordance with the manufacturer's instructions by competent persons and that it meets the requirements of the appropriate Building Regulations and relevant electrical qualifications. The Benchmark Checklist can be used to demonstrate compliance with Building Regulations and should be provided to the customer for future reference.

Installers are required to carry out installation, commissioning and servicing work in accordance with the Benchmark Code of Practice which is available from the Heating and Hotwater Industry Council who manage and promote the scheme.

Visit www.centralheating.co.uk for more information.

COMPONENT LISTING / SPARE PARTS

Cold Water Inlet Set	LOOSE
15 x 22mm Tundish	LOOSE
Temperature & Pressure Relief Valve	FITTED
Expansion Vessel & Mounting Bracket	LOOSE
Immersion Heater(s) - Capacity and configuration dependant	FITTED
Installation Manual	LOOSE
Benchmark Logbook - Found at the back of this manual	LOOSE
2-Port Zone Valve 28mm	LOOSE
High Limit Cylinder Overheat Thermostat	LOOSE

GENERAL INSTALLATION REQUIREMENTS

The cylinder must be installed, commissioned and maintained by a competent installer holding a current G3 unvented qualification, and/or being a member of a competent persons' scheme. Once the unit is installed and commissioned, the user must be given an explanation of the operation of the cylinder and its key safety components. In addition, the end user must be given this installation manual for future reference.

STORAGE AND HANDLING

Care must be taken when handling the product. Seek assistance when moving the product as required, and follow safe working practices and lifting techniques to avoid injury or product damage. Before installation, the cylinder must be stored upright in its original packaging, on a secure, level surface within a dry and frost-free environment.

SITING THE UNIT

This product must be installed vertically on a flat base that is capable of supporting the maximum-fill weight of the cylinder. For each metre an outlet is above the cylinder, the supply pressure of the hot water will be reduced by 0.1 bar.

The minimum recommended cupboard size is 650mm square as the product diameter can vary (capacity and configuration dependant) between 475mm to 580mm. This is to ensure that there is access to the cylinder safety controls/immersion heaters and for future valve maintenance or replacement during service. Therefore, please ensure all connections are outward facing towards a door or similar opening for this purpose.

DO NOT OBSTRUCT THE CYLINDER IN CASE IT NEEDS REPLACING

Areas subject to freezing should be avoided. If the cylinder is sited outside of a heated area of the dwelling, such as a garage or outbuilding, ensure the provision of adequate frost protection, such as insulation of exposed pipework. Pipe lengths must be kept to a minimum to ensure minimal losses.

COLD WATER INLET CONTROL SET

Included in your unvented safety components is a multibloc inlet control group. This single unit is standard issue for many unvented water systems, and comprises of many different safety valves, housed into a single brass casting. This is detailed as follows:

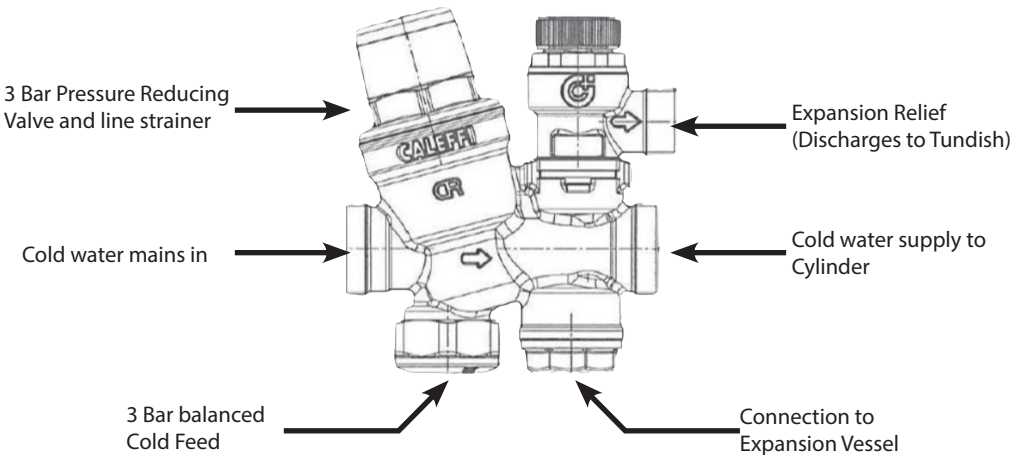

WATER SUPPLY

We recommend that the maximum on-site water demand be assessed and the water supply be tested to ensure it meets the following requirements. This should be sourced from mains water only - your warranty does NOT include the use of wells or bore holes as a water supply.

It must be noted that a high mains water pressure does NOT always guarantee a high flow rate. Ensure a working (not static) condition site pressure reading is taken. The minimum mains water supply requirements should be 0.15MPa (1.5 bar) working pressure, and a 20 litres per minute flow rate available. Where mains inlet pressures may exceed 10 bar, an additional upstream pressure reducing device should be fitted in addition to the cold water inlet set provided.

The mains supply pipe-work should be a minimum of 22mm. This could warrant the replacement of any existing 1/2" (15mm) cold mains pipe-work.

The water supply must be of a wholesome water quality, defined as Fluid Category 1 in the Water Supply Regulations 1999. In areas of hard water content (CaCO_3) greater than 200ppm, treatment should be installed.

CHANGE OF WATER SUPPLY

The changing or alternation of one water supply to another can be detrimental on the operation and/or life expectation of the product and its accessories. Where a water supply changeover occurs, e.g. a rainwater tank supply, bore water supply, desalinated water supply, public reticulated water supply or water brought in from another supply, then water chemistry information should be sought, or should be tested to ensure the supply will meet the requirements given in these guidelines for our manufacturer's warranty to apply.

CYLINDER SUPPLY AND SAFETY DISCHARGE SCHEMATIC

VERTICAL CYLINDER LINE DRAWING

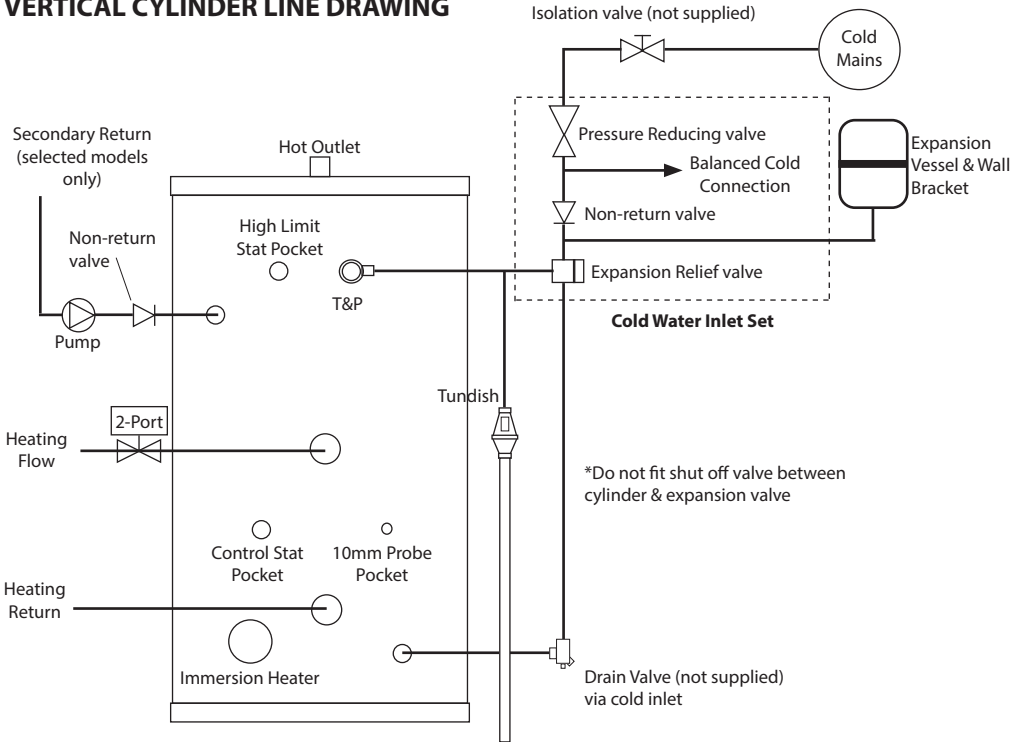

HORIZONTAL CYLINDER LINE DRAWING

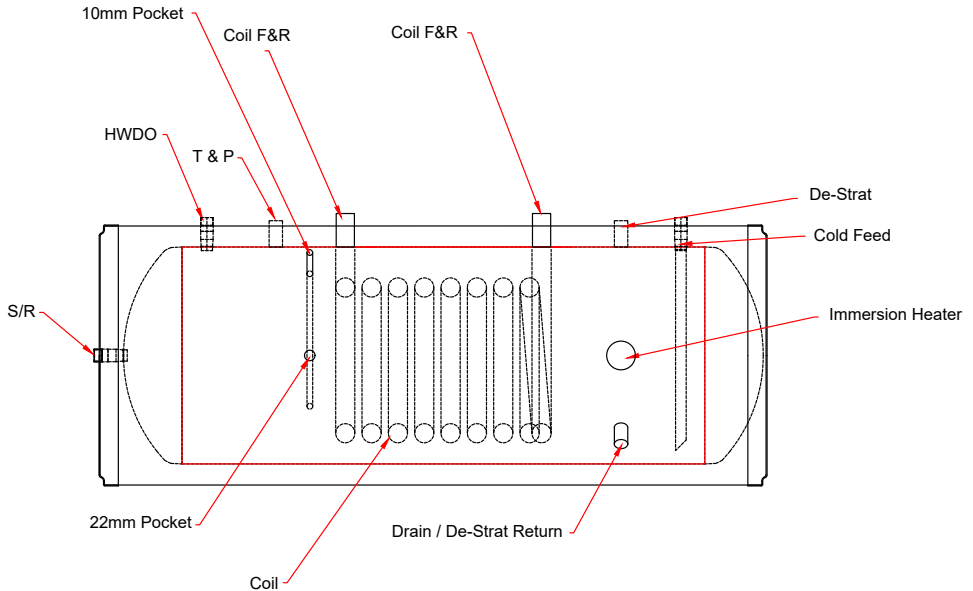

GENERAL INSTALLATION AND COMMISSIONING

PLEASE NOTE - THE MAINS WATER CONNECTION BOSSES AND THE OLIVES & GLAND NUTS SUPPLIED AS STANDARD ON THIS INDIRECT ARE 3/4" BSP. COIL CONNECTIONS ARE 1" BSP ON STANDARD CYLINDERS, 3/4" BSP ON SLIMLINE UNITS.

COLD MAINS PIPEWORK

The cold mains pipework should be a minimum of 22mm, through to the cylinder installation to ensure that hot water flow requirements for taps and shower heads are met. Care should be taken to avoid inefficiency and heat transfer where cold water pipes run adjacent to hot water or heating pipework. Install an isolating valve (not supplied) to the cold mains pipework. A 22mm BS1010 stopcock or a quarter turn full-bore lever valve should be used rather than a screwdriver slot or other similar valve. Make the connection to the cold feed of the cylinder, incorporating a drain valve.

Position the inlet control set above the Temperature and Pressure Relief Valve (T&P) found on the side of the cylinder. This ensures the cylinder does not need to be drained in order to service the inlet control. Ensure the directional flow arrow on the inlet control follows the flow of water.

Mount the external expansion vessel in a suitable position to the wall using the provided bracket, and connect the pipework to the expansion vessel connection provided on the cold water inlet set. There must be no obstruction or flow restriction between the cylinder and the expansion vessel.

You must ensure that the cylinder does not fill to a pressure of greater than 3.0bar. If there are to be any showers, bidets, or monobloc taps in the installation (or wherever mixing/blending water fittings are installed) then a balanced cold supply is necessary, otherwise there is the danger of a mains fed cold service pressure leaking into the controlled hot circuit. Such back pressure would be detrimental to the system and could cause the unwarranted operation of discharge valves.

It is essential that the cold service be balanced throughout the property by taking the cold services from the **balanced cold connection** on the inlet control set. Should this not be possible an independent 3.0bar inlet pressure reducing valve must be installed into the cold supply of any such mixed fitting, suitably positioned so as to not compromise water flow to the cylinder. An outside hose tap may still be connected direct to the incoming cold supply if desired.

HOT WATER PIPEWORK

The majority of the hot water distribution pipework should be 22mm, possibly reduced to 15mm or 10mm dependant on the type of tap. Keep the hot draw off pipework to a minimum to maximise the transfer speed of hot water from cylinder to outlet. We would advise against soldering tappings immediately to the hot water drawoff, as this reduces any inherent risk of flux landing on the immersion heater and causing premature corrosion to the connection and unit.

If the balanced cold connection is not provided, do not use monobloc mixer taps or showers. This would cause the unit to back pressurise and result in discharge. Ensure that the top of the vessel is accessible for servicing.

PRIMARY COIL CONNECTIONS

1" connections are provided for the high flow primary circuit which must be positively pumped. Primary flow and return connections are interchangeable to suit site conditions. This will not affect reheat times.

Ensure a corrosion inhibitor suitable for stainless steel coils is used in conjunction with the primary circuit.

Sealed or vented primary circuits comply with normal installation practices. Although the coil is capable of handling 6.0bar pressure, the primary pressure should exceed no more than 3.0bar. The heat pump used must be sure to have an effective thermostatic control – The two-port zone valve should be installed on the primary flow pipework leading back to the Heat Pump. The direction of the flow arrow should align with the primary flow connection. The maximum operating temperature of primary coils should be 85°C. Extra thermostat bosses come supplied on all heat pump cylinders.

CONTROL THERMOSTAT

Heat pump cylinders come provided with at least one high limit cylinder stat. The stat functions as a heat source isolation safety device with the included 2-port zone valve in the event of overheating, and should be installed as per the wiring diagrams set out in this manual, and should be positioned in the top sensor pocket of the cylinder.

When the heat output from the Heat Pump is set to maximum, please ensure that the flow output and circuit pressure from the Heat Pump is also set appropriately so that the vessel can achieve the desired temperature.

Twin probe pockets are positioned further down the cylinder, and are to be used for the temperature sensor provided with your chosen heat pump.

Additional thermostat pockets are provided on solar twin coil units at both the top of the cylinder for high limit cut out and at the coil for temperature control.

Horizontal heat pump cylinders come provided with a traditional 22mm control thermostat pocket halfway up the cylinder, but also utilise a 10mm probe pocket that feeds down into the bottom half of the cylinder as seen in the diagram.

This provides both greater accuracy and flexibility in monitoring the cylinder, but also ensures a greater level of hot water capacity from the unit.

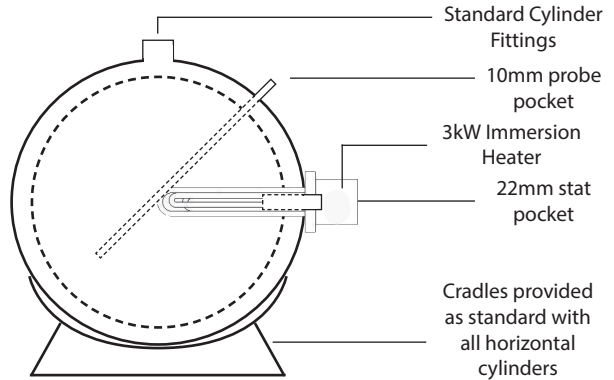

RECOMMENDED STORAGE TEMPERATURE

For domestic usage a temperature set of 50°C-55°C with heat pumps is the norm. This is above recognised bacterial growth levels and low enough to prevent nuisance tripping of limit thermostats or unnecessary scaling.

HEATING CONTROL

A 28mm 2-port zone valve is provided with your heat pump cylinder for use in an s-plan system, and must be installed as per building regulations to isolate the heating supply to the domestic hot water unit when the vessel reaches the required temperature. An arrow will be visible on the valve to demonstrate flow direction, and the valve must be installed as such.

If a full diverting 3-port valve is chosen for use with a y-plan system instead, it must also be installed as per building regulations. In the event of failure, the valve must be orientated so that the hot water cylinder is isolated from any heat source. A typical arrangement is shown below but is not extensive to all 3-port zone valve models, please check your own valve and arrange as appropriate.

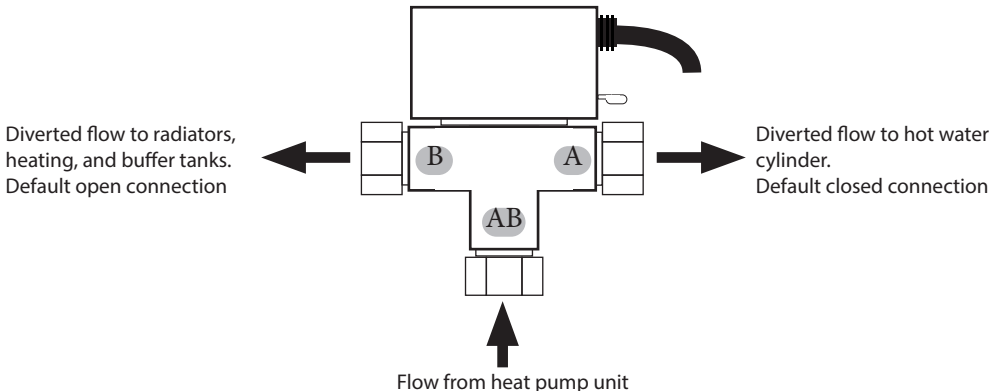

THERMAL PASTE

- Ensuring correct stat probe positioning within the dry pocket
- Securing the probe to avoid withdrawal or partial contact
- Correct application of **high-thermal-stability heat paste** to:
 - o Maintain a positive heat-sink seal
 - o Eliminate air gaps that inhibit heat transfer
 - o Provide consistent sensor-to-pocket contact
 - o Improve response accuracy and reduce nuisance heat pump cycling

These refinements are best-practice measures to support reliable operation, particularly in systems where accurate temperature feedback is critical.

HEAT PUMP COMPATIBILITY

Our heat pump cylinders have been designed to function with all heat pump units. The system should be installed as per the instructions provided with your chosen heat pump, with provisions as appropriate made for the pipework and for buffer vessels if required to maintain a suitable COP.

All plumbing and wiring installations should be completed as per instructions detailed in your chosen heat pump's manual. Example wiring instructions are detailed in this manual. Your hot water cylinder should be installed in close proximity to the heat pump to minimise heat losses from the pipework and maximise reheat performance, but should not be installed outside.

Pipework from the heat pump to the cylinder should be 28mm and capable of handling a flowrate in excess of 25L/min without significant pressure drop across the system. The use of smaller bore pipework will be detrimental to the performance of the heat pump and the cylinder coil, resulting in decreased flowrates, slower recovery and higher energy costs.

NOTE: Due to the working nature of air source heat pumps, hot water recovery times can change seasonally, resulting in slower reheats in winter.

HEAT PUMP MEDIA

The cylinder heating coil is suitable for use with either propylene glycol or water treated with inhibitors as would be commonly used in conjunction with a heat pump. For both retrofit and new installations with glycol or water, it is recommended that a magnetic filter is installed within the system to extend the life and effectiveness of both the cylinder and the heat pump. The cylinder warranty is not affected if a filter is not fitted in the system.

If a plate heat exchanger is used in conjunction with the heat pump to avoid use of excess glycol, we would recommend utilising the cylinder on the directly heated side of the exchanger with the heat pump, to ensure efficient reheat times. If the cylinder is fitted on the counter-side of the plate heat exchanger with radiators and buffer tanks, the flow rates in and out of the plate should be optimally balanced to ensure maximum heat transfer in the system.

Propylene glycol with a toxicity rating of class 1 must be used in the system if installing anti freeze. Ethylene glycol is toxic and **MUST NOT** be used in case of contamination with potable water.

SOLAR COIL INSTALLATION

INDIRECT SOLAR SINGLE AND TWIN COIL MODELS

Indirect solar cylinders have a coil at the bottom of the cylinder for connection to the the solar thermal system. For indirect solar twin coil cylinders connect only the lower coil to the solar thermal system. Connection procedure to solar is identical for all products. Connect the solar flow to the upper connection and the return to the lower connection. The solar temperature control sensor (supplied as part of the solar package) inserts into the pocket directly above the coil and is retained with the wiring grommet supplied. High limit control of the solar input is monitored with the single high limit thermostat which inserts into an upper pocket at the the same height as the T&P relief valve.

For installations where solar panels are higher than the cylinder connect the stat to interrupt the electrical supply from the solar pump and / or solar control panel. For installations where the solar panels are lower than the cylinder connect the high limit thermostat to close a two-port valve (not supplied) installed on the solar return pipework. With solar indirect twin coil the upper coil connects to the boiler flow and return. The dual control / high limit thermostat installs into the pocket immediately above the upper coil and is wired to activate the two-port valve (supplied) installed into the boiler primary flow.

This cylinder as supplied is not designed for installation with a boiler and heat pump without extra controls listed below.

Should it be the desire to connect the solar indirect twin coil cylinder to a boiler/Heat pump then further dual control / high limit thermostat and two port-valve will be required and both coils and safety controls must be installed as per the single coil boiler format in our standard indirect installation manual. Both the additional thermostat and two port valve may be purchased from the cylinder manufacturer.

SECONDARY CIRCULATION

Secondary return connections are supplied as standard on indirect cylinders of 200L and above. Where secondary circulation is unavoidable for smaller capacity cylinders, a circulator suitable for potable water must be used in conjunction with a non-return valve to prevent backflow. The return connection should be made with a swept tee into the cold feed pipework directly above the drain connection. It may be necessary to incorporate an extra expansion vessel into the circuit to accommodate an increased system volume in larger secondary circulation systems.

IMMERSION HEATER - ALL MODELS

All standard supply is with immersion heater elements of 3 Kilowatt output at 240 Volts, Incoloy elements, double pole thermal isolation and a 1¾" BSP threaded head.

In a heat pump cylinder, this should be wired as appropriate either via the heat pump controller or to an external immersion heater controller to enable a weekly bacterial pasteurisation cycle above 60 degrees to eliminate bacterial growth.

SIDE ENTRY IMMERSION HEATERS - HORIZONTAL MODELS

For horizontal cylinders with side entry immersion heater(s) these cannot heat water below the level of the immersion heater itself and are designed to be used as an emergency heat source when the heat pump is not available. The position of the immersion heater(s) will allow approximately 50% of the total water volume to be heated. Should a greater volume be required when using immersion heater(s) only, then a potable water destratification pump will be required to circulate water from the destratification connection at the top (when installed) of the cylinder and returning into the drain connection under the cylinder. The drain cock must at a low point in this pipework. We would suggest the destratification pump is wired to operate in conjunction with the immersion heater operation. This arrangement is required if the immersion heater is used for periodic raising of the storage temperature for the purposes of sterilization against bacterial growth.

ELECTRICAL CONNECTION - 3kW - ALL MODELS

This appliance must be earthed. It is suitable for a 240 volt A.C. supply only. The electrical installation should only be carried out by a suitably qualified electrician in accordance with latest I.E.E. regulations. Ensure the electrical supply is isolated before working on the system.

The electrical supply to each immersion heater must be fused at 13A via a double pole isolating switch with a separation of at least 3mm to both poles to BS 3456.

The cable must be 2.5mm² heat resistant (85°C HOFR) sheathed flex complying to BS EN 50525. Do not use a cable of lesser rating.

For immersion heaters other than 3kW consult wiring requirements supplied with the immersion heater.

Do not operate the immersion heater(s) until the unit is full of water. If any sterilisation liquid is in the cylinder do not operate the immersion heater(s) as this will cause premature failure.

This device must be earthed.

Earth connection, (green & yellow), should be made firmly to the earth post marked "E", using the terminal attachments provided. Live connection, (brown), from the mains supply cable to the thermostat terminal marked "L". Neutral connection, (blue), from the mains supply cable to the thermostat terminal marked "N".

COMMERCIAL/HEAVY DUTY USE

For commercial/heavy duty installations with constant usage/reheat requirements or where an external programmer designed for immersion heaters is not present then Titanium immersion heaters must be fitted in order to comply with the warranty.

RECOMMENDED TEMPERATURE SETTINGS - IMMERSION HEATER

For domestic usage a temperature set of 55°C-60°C is the norm. This is above the growth temperature area for Legionella and low enough to prevent nuisance tripping and unnecessary scaling.

THERMOSTAT OPERATION

The thermostat has an adjustable control operating between 20°C and 65°C. The usual desired domestic setting is between 55°C and 60°C. The thermostat is supplied set at 60°C. For setting the stat, turn fully clockwise to the maximum, and then anticlockwise (back off) approximately a quarter of its travel. Then make minor adjustments to suit your personal taste.

THERMAL CUTOUT

If the cylinder begins to overheat (80°C), the thermal cut-out will activate, isolating both the live and negative connections within the immersion heater. This may also happen during a power spike. For resetting, isolate the power supply and allow the cylinder to cool down. Remove the head cap and press the high limit cut-out reset button on top of the thermostat. Should nuisance tripping occur, consult a qualified electrician to investigate the power supply and/or the thermostat itself.

REPLACEMENT IMMERSION HEATERS - ALL TYPES

Replacement immersion heaters are available in all formats for your water heater. These should be obtained via ourselves to ensure the correct specification is supplied, and our warranty is not compromised. The standard heater has incoloy elements, a 1¼" BSP threaded head and standard rating of 3kW at 240 volts. Check the label detail on the head before ordering, as alternative specifications are available.

The 'O' ring on the head of the immersion heater should be correctly positioned and lubricated with a WRAS approved silicon lubricant before fitting. Screw in by hand until almost sealed and then gently finish tightening as the 'O' rings will seal easily. Remake the wiring connection as per instructions provided.

INSULATION OF THE TEMPERATURE & PRESSURE RELIEF VALVE

Components for insulating the T&P are supplied in order to retain heat and energy. Installation instructions are provided with the insulation cover.

DISCHARGE ARRANGEMENT

The diagram opposite was taken directly from UK government Building Regulations Part G: 2016.

This information is not exhaustive. If in doubt, seek advice. Full details of Building Regulation G3, is available from: www.planningportal.gov.uk

The discharge from both the temperature, and expansion relief valves can be joined together via a 15mm end feed tee. Water should only be discharged when there is a fault with the system, and be visible at the tundish. (Consider a safety device to alert those of impaired vision or mobility when this occurs.)

Discharge water must not be allowed to collect in the pipe-work but rather flow freely to the tundish. This should be vertically mounted, in a visible location, in the same space as the cylinder, and fitted as close as possible within 600mm of the safety device (the relief valves). The discharge pipework must be in accordance with Part G3 of the Building Regulations. These are as follows:

- The discharge pipe (D2) from the Tundish should have a vertical section of pipe 300mm long below the Tundish before any elbows or bends in the pipework.
- This pipe should then be installed with a continuous fall of at least 1 in 200 thereafter.

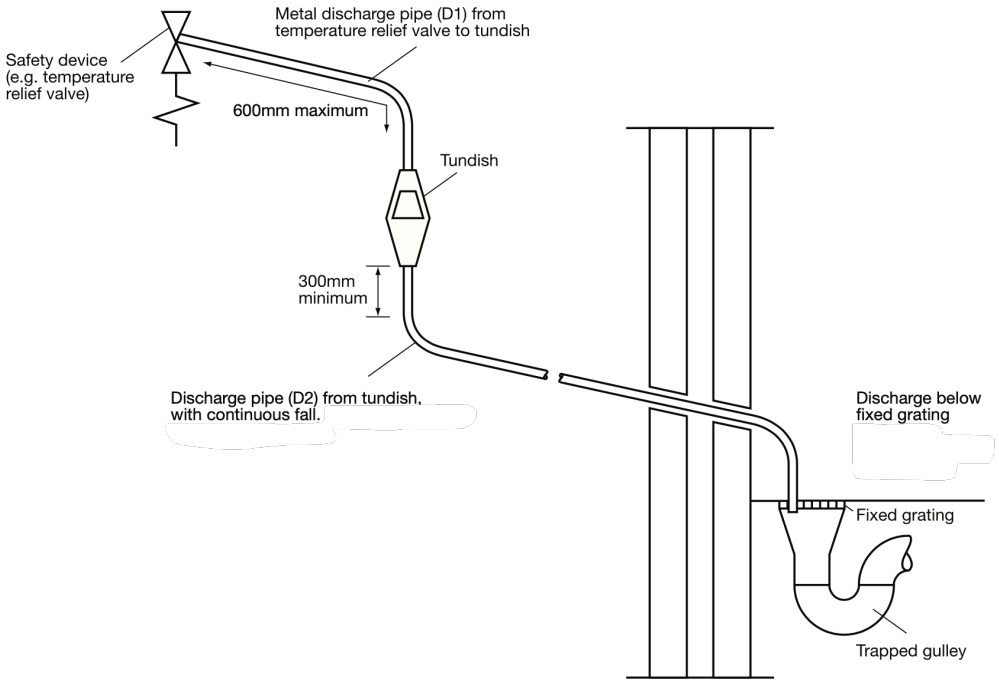

- The pipe must be at least one pipe size larger than the nominal outlet size of the safety device (unless its total equivalent hydraulic resistance exceeds that of a straight pipe 9m long i.e. discharge pipes between 9m and 18m equivalent resistance length should be at least two sizes larger than the nominal outlet size of the safety device, between 18 and 27m at least 3 times larger and so on.) Bends must be taken into account in calculating the flow resistance. An alternative approach for sizing discharge pipes would be to follow the BS 8558 Specification for the design installation, testing and maintenance of services supplying water for domestic use within buildings and their curtilages.

Discharge pipework should terminate in a safe place where there is no danger to persons in the vicinity of the discharge. Examples of acceptable discharge arrangements include:

- To a trapped gully with the outlet below a fixed grating and above a water seal.
- Downward discharges to low level, within 100mm, above external surfaces such as a car park, hard standing, grassed area with a protective wire cage to prevent contact but retaining visibility of discharge.
- Into a metal hopper at high level with a metal downpipe and a clearly visible termination point or onto a roof capable of withstanding high temperature discharge at least 3m away from any plastic guttering.

Building Regulation G3 allows non-metallic pipework within the tundish discharge (D2). The discharge pipe (D2) should be made of a) metal or b) another material that has demonstrated it can safely withstand high temperature water discharges and is clearly and permanently marked to identify the product and the performance standard. The discharge should not be connected to a soil discharge stack unless it can be demonstrated of safely withstanding high temperature water discharges, in which case it should;

1. Contain a mechanical seal, not a water trap, which allows water into the branch pipe but not foul drain air to be ventilated through the tundish.
2. Be a separate branch pipe with no sanitary appliances connected to it.
3. Plastic pipes used as branch pipes with the discharge should be Polybutalene (PB) or cross linked polythene (PEX) complying with national standards such as Class S of B7291-2: or Class S of BS7291-3 respectively.
4. Be continuously marked with a warning that no sanitary appliances should be connected to the pipe.
5. Plastic pipes should be joined and assembled with fittings appropriate to the circumstances in which they are used as set out in BS EN ISO 1043-1.

Queries regarding specific discharge arrangements should be directed to your local building control office.

TYPICAL WIRING - S PLAN, SINGLE ZONE

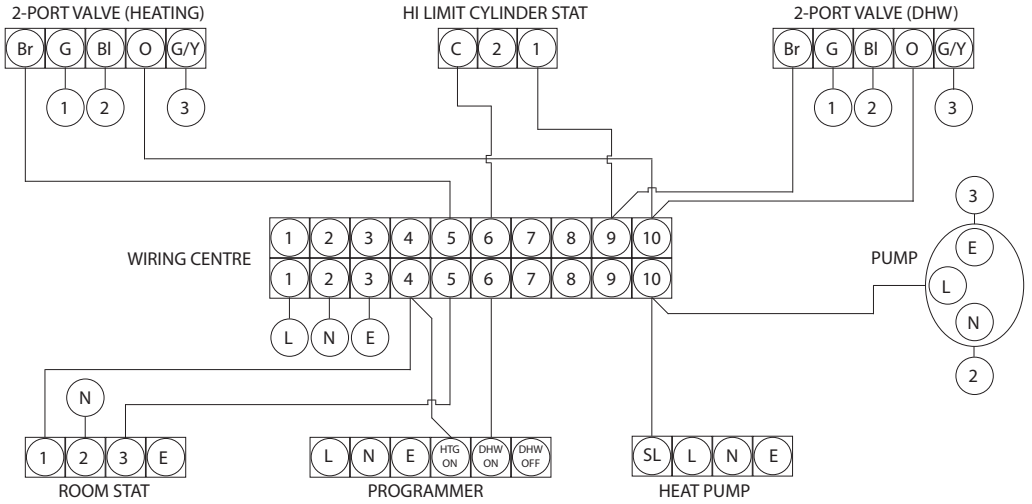

TYPICAL WIRING - Y PLAN (5-WIRE 3-PORT FULL DIVERTING VALVE)

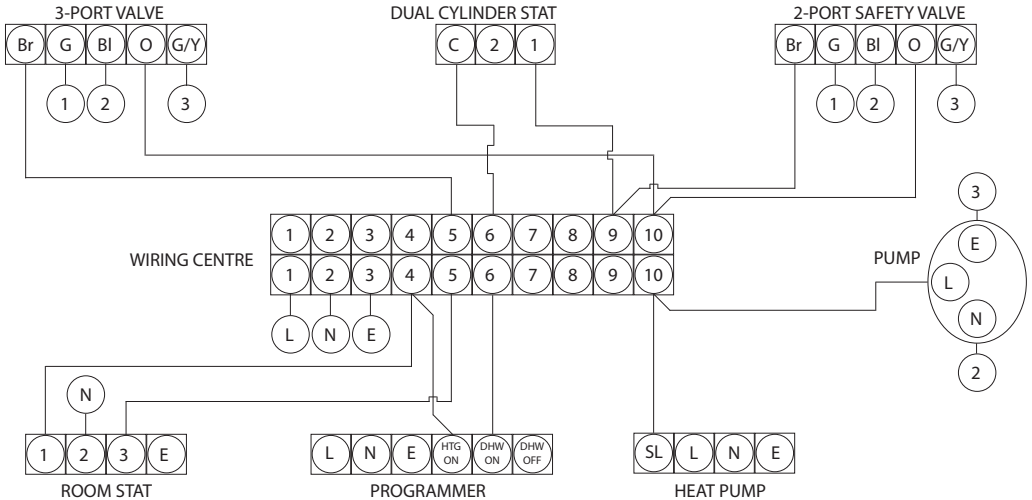

COLOUR CODES

W = WHITE **G** = GREEN **Bl** = BLUE **G/Y** = GREEN/YELLOW **Br** = BROWN
L = LIVE **N** = NEUTRAL **C** = COMMON **SL** = SWITCH LIVE **E** = EARTH

TYPICAL WIRING - Y PLAN (3-WIRE 3-PORT FULL DIVERTING VALVE)

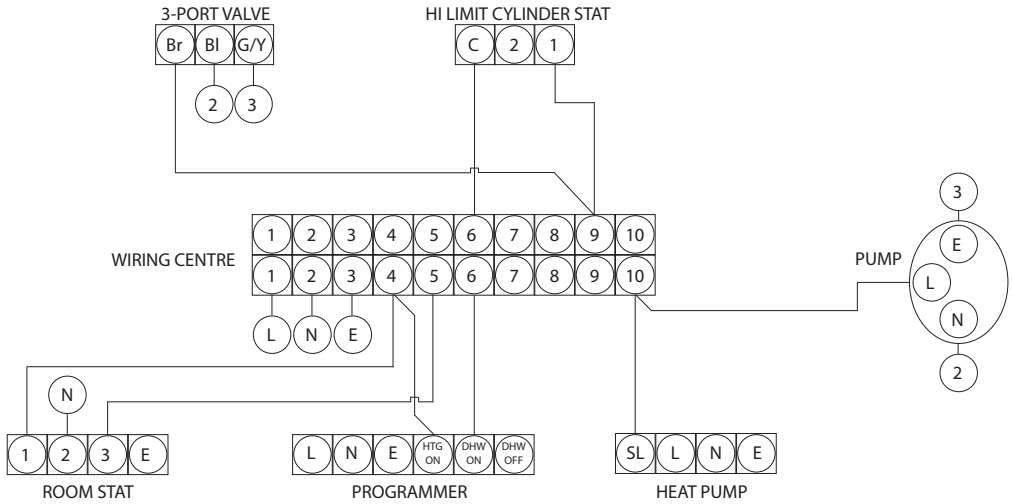

If the 3-port valve itself has not been fitted to building regulations to isolate the heat source from the unvented hot water tank in event of failure, a safety 2-port valve MUST be fitted on the flow into the cylinder coil and controlled via the high limit thermostat provided in the unvented kit, example wiring diagram for this is seen opposite.

If fitted as correct orientation detailed in this manual, and wired as above to isolate the cylinder from heat source in event of failure, additional valves should be implemented as per the heat pump installation manual to control heat sources to radiators and underfloor systems.

SYSTEM CONTROL

The wiring diagrams shown in this manual are only to demonstrate the necessary installation of safety features of 2-port wiring and stat cut-offs from overheat. The system should be controlled via the thermal probe that comes with the heat pump, and should be installed and wired as per manufacturer's instructions.

COMMISSIONING - FILLING THE SYSTEM

Check all connections for water tightness including factory made connections, as these may become loose in transit. The expansion vessel should be 3 bar (45PSI).

The hot tap furthest away from the cylinder should be opened before filling the system to purge air and flush any disturbed particles.

The pipes should be flushed before use. The remaining taps should be opened in turn to purge air from the system before turning on the electrical supply.

SAFETY VALVE CHECKS

A problem is occurring if water is released from either safety valve during the heat up process (temperature relief and expansion relief.) This must be rectified before continuing. Both valves should be opened slowly one at a time, and then together, allowing as much water as possible through the tundish. Check that the discharge pipework is cleared of obstruction, free flowing, and without spillage over the tundish. Check that the valves reseal correctly when released.

DRAINING PROCESS

Isolate the unit from the electric supply to prevent immersion heater burn out. Isolate the unit from the cold mains. Attach a hose to the draining tap. Ensure this reaches to a level below the unit for creating an effective siphon so that the maximum amount of water is drained from the unit. Open the hot tap closest to the unit and open the draining tap.

Caution: Water drained off may be hot.

DISCHARGE AT THE TUNDISH

IF WATER IS FLOWING THROUGH THE TUNDISH THIS INDICATES DISCHARGE FROM ONE OF THE SAFETY VALVES AND INDICATES A FAULT IN THE SYSTEM. CONTACT A COMPETENT PLUMBER OUT TO SERVICE OR DIAGNOSE THE SYSTEM.

BUFFER VESSELS

All our heat pump cylinders are compatible with buffer vessels. We recommend the provision of our own buffer units in combination with the heat pump system to minimise pressure drops and maximise performance.

Stainless steel buffer vessels are preferred, as they will extend the lifespan of the heating coil within the cylinder. It is recommended if a mild steel buffer is used, to incorporate a magnetic filter into the return from the vessel into either the cylinder coil, or towards the heat pump.

INTEGRATED BUFFER VESSELS

Our heat pump cylinders can optionally come with an integrated buffer vessel in the bottom of the finished tank. These come with 4x 1" connections and a probe pocket for temperature monitoring.

The buffer units in this style of cylinder, due to not having an air release as per standalone buffers, require specific installation to remove air from the units upon commissioning.

As seen in the diagram below, flow deflectors are used in the left hand side and bottom right of the 1" connections. These are used to direct flow into the buffer, consequently encouraging mixing of the differing temperatures in and out of the vessel, and reducing stratification. These 3 connections, labelled with "A", "B", or "D" on the diagram, are interchangeable to suit the installation, but a suggested connection method is shown below.

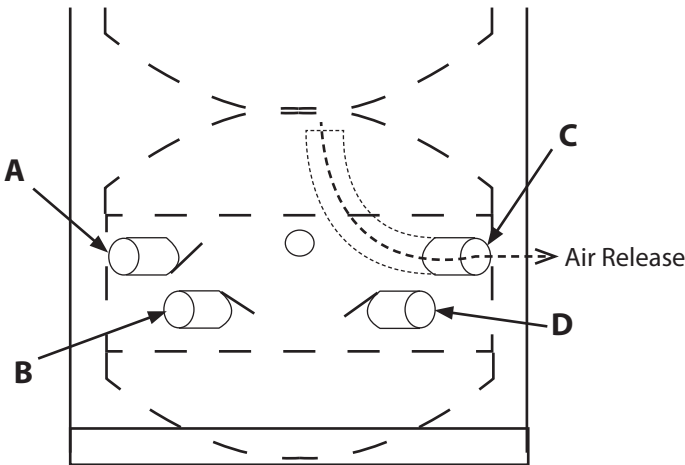

Connections for the integrated buffer are labelled as follows:-

- A - Heat Pump Flow
- B - Heat Pump Return
- C - Heating Flow & Air Release
- D - Heating Return

In addition, a probe pocket is provided in the middle of the cylinder for temperature monitoring/control.

INSTALLATION SCHEMATIC

Detailed on the next page is an example of how heat pump cylinders with integrated buffer vessel may be installed.

This schematic is intended for guidance only. Any setup should always refer to the heat pump manufacturer's literature for their preferred method of installation and positioning of any other required components, such as filters, flow meters and pressure gauges.

This schematic does not demonstrate the connection of any potable water pipework, and is only indicative of connections to the heat pump, space heating (such as radiators) and the cylinder coil. For a potable connection diagram, please refer to the Cylinder supply and safety discharge schematic on pages 4 and 10 of this manual.

It is worth noting that in this example schematic, the return connection from the cylinder coil tees into the buffer connection returning directly to the heat pump. This is recommended over returning the cylinder coil into the buffer, as this can make the buffer run colder, reducing heat times for both the cylinder and space heating. Additionally, returning the cylinder coil connection straight to the buffer (as cold) will increase the COP from the heat pump, increasing efficiency of the system.

HEAT PUMP SUPPLIED

Typical schematic showing the buffer store and the cylinder coil fed directly from the heat pump. The space heating is then drawn from the buffer store.

SCHEMATIC FOR INDICATION PURPOSES ONLY

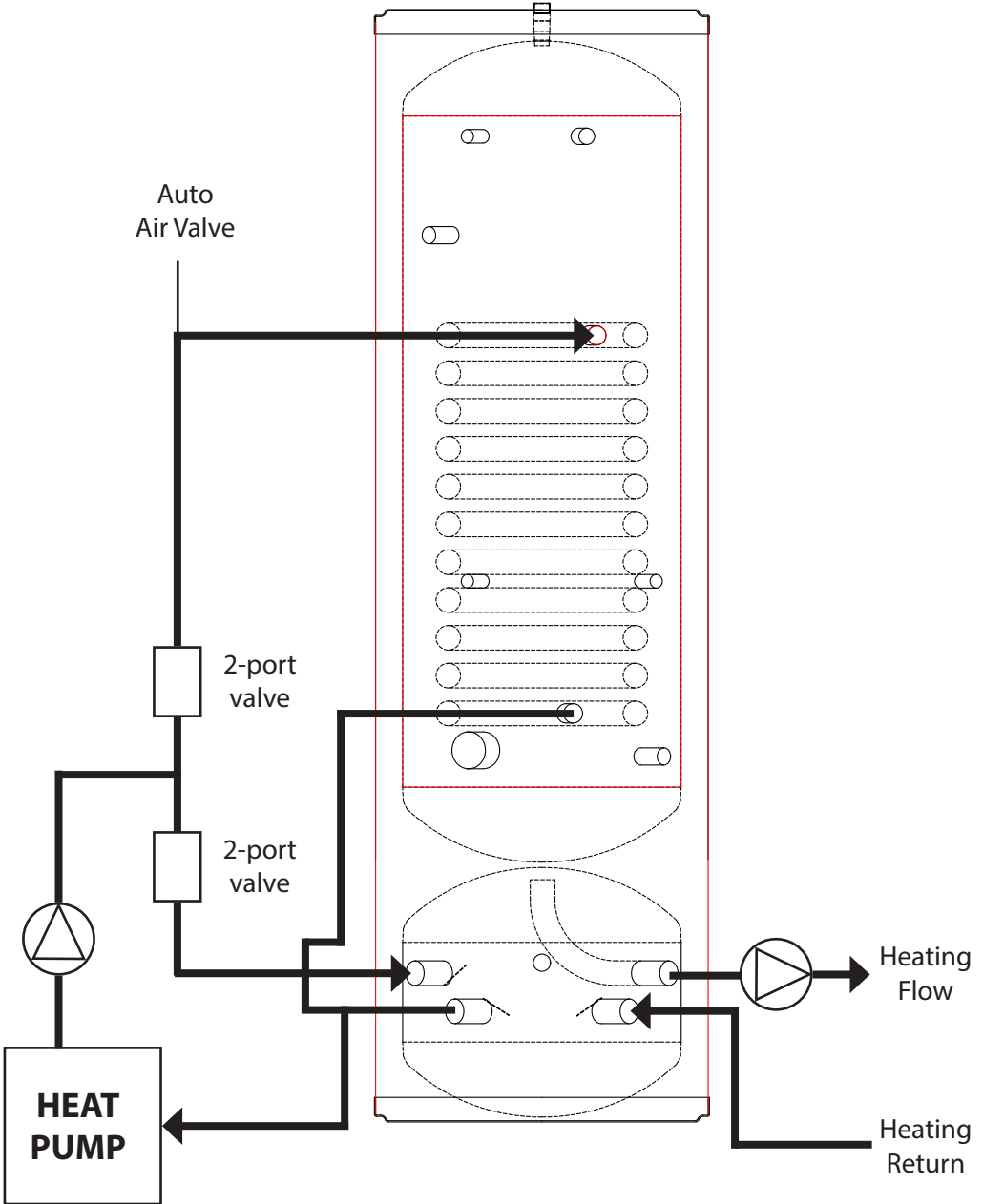

SERVICE AND MAINTENANCE

- **Servicing must be carried out annually by a competent installer.**
- **Any spares used must be purchased from us.**
- **Safety devices must not be bypassed. Do not use the unit if safety features are not fully operational.**
- **Proof of annual servicing is required to avoid invalidating your manufacturer's guarantee.**
- **Upon installation of the unit the installer must complete the accompanying commissioning certificate at the rear of this manual.**

ANNUAL SERVICING PROCESS

This must be conducted by a competent installer on an annual basis, ideally at the same time as the annual boiler service:

1. The expansion relief valve should be eased open to allow water to flow for a minimum of 5 seconds. Close the valve and make sure it resets correctly. Repeat this procedure with the temperature & pressure relief valve. Ensure that the discharge pipework is cleared and allowing a free flow of discharge.
2. Ensure all fitted immersion heaters are working correctly. They should be controlling the water temperature between 55°C and 60°C.
3. Make sure the pressure in the expansion vessel is set to 3 bar. This is done by turning off the water supply to the unit and opening a hot tap first. Air or CO₂ can be used for repressuring the expansion vessel.
4. Remove the head on the inlet control set and clean the mesh filter within.
5. Update the benchmark service record supplied after every service by the installer.

CYLINDER FAULT FINDING

PROBLEM	POSSIBLE CAUSE	REMIEDIATIVE ACTION
Water is visible at tundish	Potential discharge from T&P valve	Follow tundish/T&P fault finding
	Potential discharge from Expansion relief valve due to fault at PRV	Follow inlet control set fault finding
	Back pressure from system	Check all cold connections into mixer outlets are fed from the balanced cold service from the inlet control valve. If not, additional PRV's must be fitted.
Expansion relief valve opens when cylinder is heated	Possible fault at Expansion Vessel	Follow expansion vessel fault finding
Cylinder appears to be leaking from inside the steel case	Loose cylinder connection - notably from hot water outlet	Check all connection points including the immersion heaters and the hot outlet to ensure that these are not leaking, and remake joints if necessary.
Noise when operating tap or shower	Vibrating/insecure pipework	Ensure that all pipework is secured to the wall with pipe clips as appropriate.
Reduced water flow	Possible external water works being carried out	Check with local authorities and wait for works to be completed
	Lodged debris from mains at Inlet control set or PRV sticking	Strip & clean PRV/inline filter, or replace inlet control set.
No hot water available	Possible immersion heater failure	Follow immersion heater fault finding

EXPANSION VESSEL FAULT FINDING

PROBLEM	POSSIBLE CAUSE	REMIEDIATIVE ACTION
Discharge of water from relief valve into tundish	Expansion Vessel is undersized	Vessel needs resizing and installing by a qualified heating engineer.
	Pre-charge set incorrectly on vessel installation	Pre-charge requires setting when the system is depressurised according to manufacturer's recommendations.
	Vessel membrane is ruptured and may require replacement	Check schrader valve for leaks or damage. Replace vessel if necessary
	Membrane may be partially depressurised due to losses over time and require re-pressurisation	Check schrader valve for leaks or damage. Have heating system serviced and vessel repressurised or replaced.
Leak from flange or water connection	Failure of flange plate	Replace flange plate or entire vessel
	Ruptured membrane has led to internal corrosion and has caused leak in vessel	Replace entire vessel
Vessel appears full of liquid when system is cold	Membrane is fully depressurised	Replace membrane or entire vessel. Check schrader valve for leaks or damage.
Water discharges from vessel when schrader pin is depressed for inspection of pressure	Vessel membrane is ruptured	Replace membrane or entire vessel.

INLET CONTROL SET FAULT FINDING

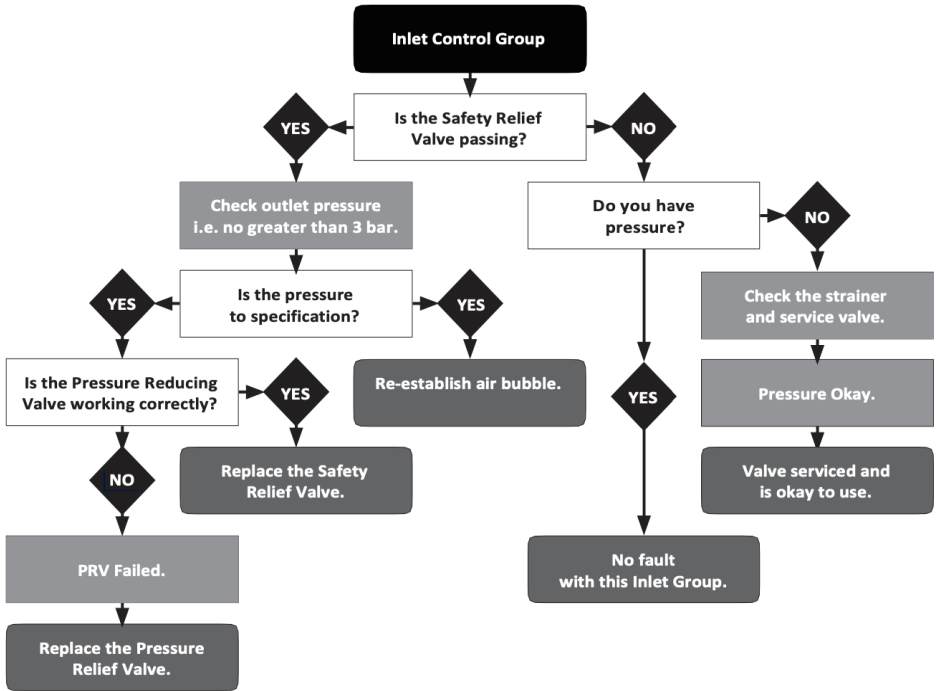

TUNDISH FAULT FINDING

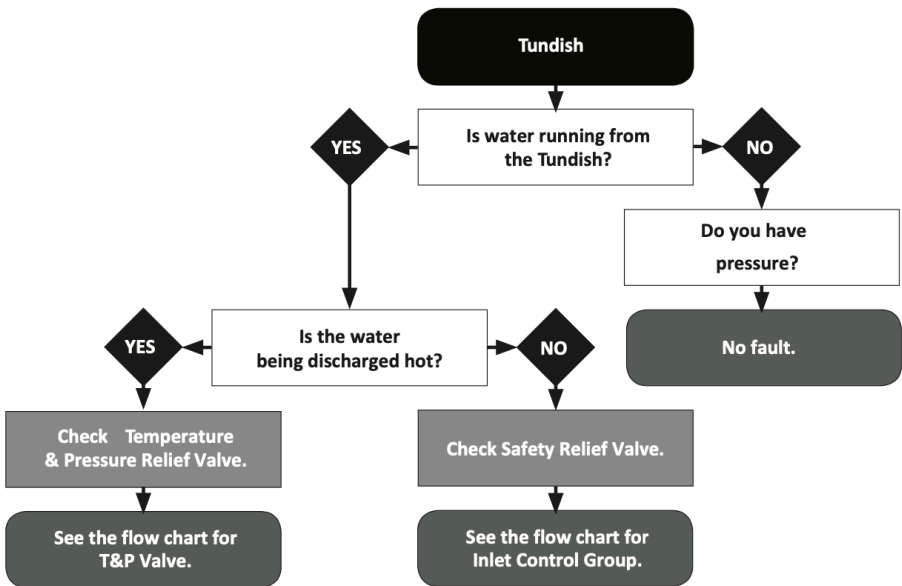

TEMPERATURE & PRESSURE RELIEF VALVE FAULT FINDING

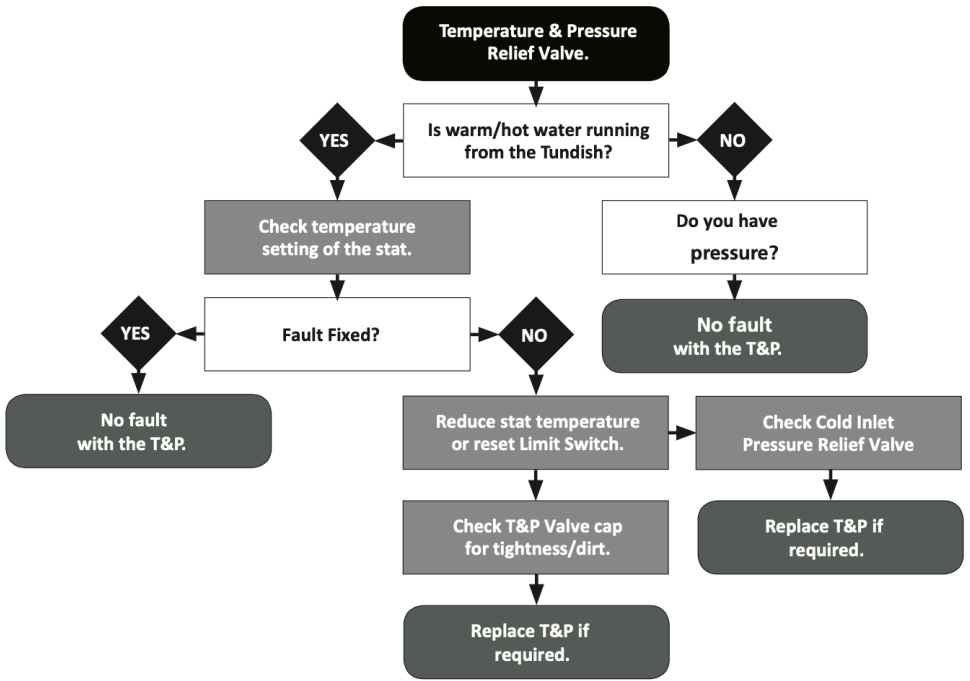

DUAL THERMOSTAT FAULT FINDING

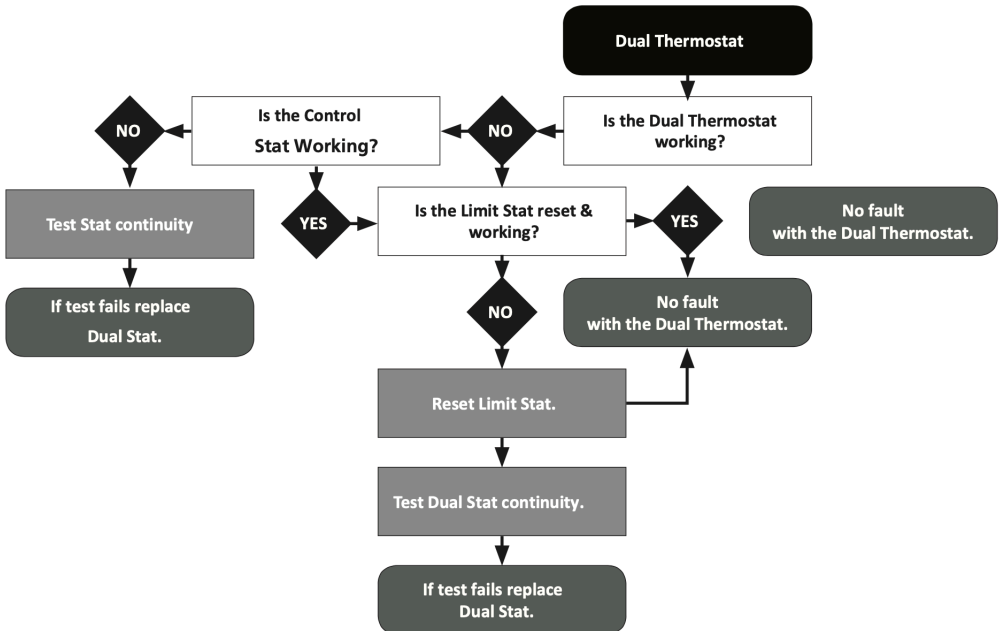

IMMERSION HEATER FAULT FINDING

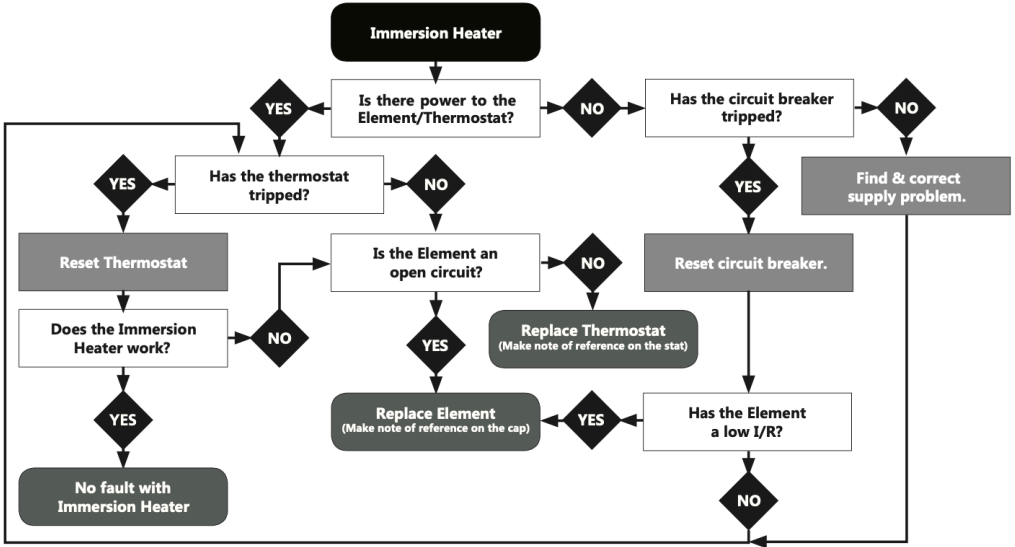

ENERGY CUTOFF FAULT FINDING

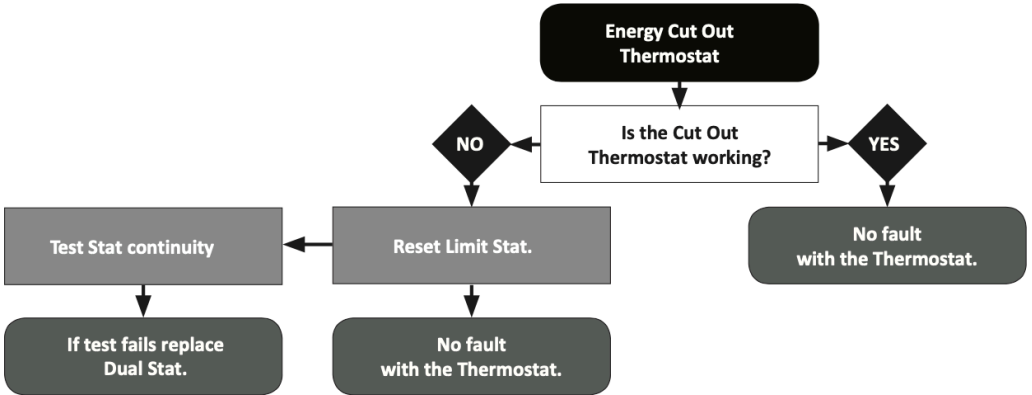

MAINS PRESSURE HOT WATER STORAGE SYSTEM COMMISSIONING CHECKLIST

This commissioning checklist is to be completed in full by the competent person who commissioned the storage system as a means of demonstrating compliance with the appropriate Building Regulations, and then handed to the customer to keep for future reference.

Failure to install and commission this equipment to the manufacturer's instructions may invalidate the warranty but does not affect statutory rights.

Customer Name _____ Telephone Number _____

Address _____

Cylinder Make and Model _____

Cylinder Serial Number _____

Commissioned by _____ Registered Operative ID Number _____

Company Name _____ Telephone Number _____

Company Address _____

Commissioning Date: _____

To be completed by the customer on receipt of a Building Regulations Compliance Certificate*:

Building Regulation Notification Number (if applicable) _____

SYSTEM PRIMARY SETTINGS (Indirect systems only)

Is the primary heating circuit a sealed or open vented system? Sealed Vented

What is the maximum primary flow temperature? °C _____

ALL SYSTEMS

What is the incoming static cold water pressure at the system inlet? _____ bar

Has a strainer been cleaned of installation debris (if fitted)? Yes No

Is the installation in a hard water area (above 200ppm)? Yes No

If yes, has a water scale reducer been fitted? Yes No

What type of scale reducer has been fitted? _____

What is the hot water thermostat set temperature? _____ °C

What is the maximum hot water flow rate at set thermostat temperature (measured at high flow outlet)? _____ l/min

Time and temperature controls have been fitted in compliance with Part L of Building Regulations? Yes

Type of control system (if applicable) Y Plan S Plan Other

Is the cylinder solar (or other renewable energy) compatible? Yes No

What is the hot water thermostat temperature at the nearest outlet? _____ °C

All appropriate pipes have been insulated up to 1 meter or the point where they become concealed? Yes

UNVENTED SYSTEMS ONLY

Where is the pressure reducing valve (if fitted)? _____

What is the pressure reducing valve setting? _____ bar

Has a combined T&P and expansion relief valve been fitted and discharge tested? Yes No

The tundish and discharge pipework have been connected and terminated to Part G of the Building Regulations Yes

Are all energy sources fitted with a cut out device? Yes No

Has the expansion vessel or internal air bubble been checked? Yes No

ALL INSTALLATIONS

The hot water system complies with the appropriate Building Regulations Yes

The system has been installed and commissioned in accordance with the manufacturer's instructions Yes

The system controls have been demonstrated to and understood by the customer Yes

The manufacturer's literature, including Checklist and Service Record have been explained and left with the end user Yes

Commissioning Engineer's Signature _____

Customer's Signature _____

(To confirm satisfactory demonstration and receipt of manufacturer's literature)

*All installations in England and Wales must be notified to Local Authority Building Control (LABC) either directly or through a Competent Persons Scheme.

A Building Regulations Compliance Certificate will then be issued to the customer.

SERVICE RECORD

It is recommended that your hot water system is serviced regularly and that the appropriate Service Record is completed.

Service Provider

Before completing the appropriate Service Record below, please ensure you have carried out the service as described in the manufacturer's instructions.

SERVICE 1 Date _____
Engineer Name _____
Company Name _____
Telephone Number _____
Comments _____

Signature _____

SERVICE 2 Date _____
Engineer Name _____
Company Name _____
Telephone Number _____
Comments _____

Signature _____

SERVICE 3 Date _____
Engineer Name _____
Company Name _____
Telephone Number _____
Comments _____

Signature _____

SERVICE 4 Date _____
Engineer Name _____
Company Name _____
Telephone Number _____
Comments _____

Signature _____

SERVICE 5 Date _____
Engineer Name _____
Company Name _____
Telephone Number _____
Comments _____

Signature _____

SERVICE 6 Date _____
Engineer Name _____
Company Name _____
Telephone Number _____
Comments _____

Signature _____

SERVICE 7 Date _____
Engineer Name _____
Company Name _____
Telephone Number _____
Comments _____

Signature _____

SERVICE 8 Date _____
Engineer Name _____
Company Name _____
Telephone Number _____
Comments _____

Signature _____

SERVICE 9 Date _____
Engineer Name _____
Company Name _____
Telephone Number _____
Comments _____

Signature _____

SERVICE 10 Date _____
Engineer Name _____
Company Name _____
Telephone Number _____
Comments _____

Signature _____

GUARANTEE AND EXEMPTIONS

The cylinder carries a 25-year guarantee against faulty materials or manufacturing, based upon the following conditions:

- Correct installation as per this document and all relevant standards, regulations, and codes of practice in force at the time.
- The Benchmark Commissioning Checklist has been completed.
- The unit has been serviced annually.
- The product has not been modified in any way, other than by us.
- There has not been any misuse, tampering, or neglect of the cylinder.
- It has only been used for the storage of potable water.
- It has not been subjected to frost damage.
- The system is fed from a public mains water supply.
- Storage temperatures have not exceeded 65°C.
- Installations made only in the United Kingdom.
- The water chemistry used in the system is found to be within the maximum allowances.
- Units are not installed with uncontrollable heat sources (e.g. wood burning stoves).
- For commercial or heavy-duty installations where constant usage and reheating is required, titanium immersion heaters must be fitted to comply with the warranty.
- The guarantee period starts from the date of purchase.
- The extended guarantee is not transferrable and rests with the original householder.

EXCLUSIONS

- The effect of scale build-up on the unit or its components
- Any labour charges associated with replacing the unit or its parts
- Any consequential losses caused by the failure or malfunction of the unit.

Note: Invoices for servicing may be requested to prove that the unit has been serviced annually. All the components fitted to/or supplied with the cylinder carry a 2-year guarantee. The guarantee starts when the cylinder is first filled.

CLAIMS

On the rare occasion of a fault occurring, we will only consider sensible claims that are submitted in full at the time when the faulty part/unit is returned to us.

We will not cover any installer claims for excessive travelling where the installer has accepted a job more than 30 miles from their base of operations.

Removal costs cannot be recovered for the collection of a faulty unit from a difficult to reach area or where cylinder access has been restricted (as per this manual guidance.)

Claims will not be accepted for units that have not been installed in accordance with this manual.

PROBLEM GUIDANCE

When a problem arises, your first point of contact is the plumber who fitted the unit (in the first year), followed by the plumber who carries out the annual servicing of your unit for you.

If your cylinder begins to leak, we will supply you with a new one. To prevent fraud, we request an up-front payment in this case while we establish the cause of the fault. The original unit must be returned to us for inspection along with a copy of your service record and commissioning checklist. Your upfront payment will be refunded as soon as it is confirmed that the cylinder has failed within the terms of our warranty.

If a component part fails within the two-year guarantee, we will send you a new one with an upfront charge. Your credit card details may be required to prevent fraud. We ask you to post the faulty part back to us by recorded delivery within a month. A refund will be issued once the part has been tested and proven to be at fault.

APPENDIX - WATER CHEMISTRY

This water heater is manufactured to suit the water conditions of most public reticulated water supplies. However, there are some known water chemistries which can have detrimental effects on the cylinder. If you are unsure of your water chemistry, you may be able to obtain the relevant water chemistry information from your local water supply authority.

*Our warranty will not apply where water stored in the storage cylinder exceeds at any time any of the following levels: - TOTAL HARDNESS 200mg/L, TOTAL DISSOLVED SOLIDS 600mg/L

CONDITIONS OF SALE 1. DEFINITIONS

"Buyer" means the person who accepts a quotation of the Company for the sale of the Goods or whose order for the Goods is accepted by the Company.
"Company" means UK Dynamics.

"Conditions" means the terms and conditions of sale set out in this document and any special terms and conditions agreed in writing by the Company and the Buyer ("Contract" means the contract for the purchase and sale of the Goods).

"Price" means the price for the Goods to be supplied and which the Buyer agrees to pay in accordance with these Conditions. "Price" means the price for the Goods including transport and insurance (if any) 1.2 Any reference in these Conditions to any provision of a statute shall be construed as a reference to that provision as amended or extended or extended at the relevant time 1.3 The headings in these Conditions are for convenience only and shall not affect their interpretation.

2. BASIS OF SALE

2.1 The Company shall sell and the Buyer shall purchase the Goods in accordance with: 2.1.1 the Company's quotation (if provided by the Company) and accepted by the Buyer; 2.1.2 the Contract to the exclusion of any other terms, subject to which any such quotation or offer is accepted, or purported to be accepted.

2.2 Any variation to these Conditions (including any special terms and conditions agreed between the parties) shall be inapplicable unless agreed in writing by the Company and the Buyer.

2.3 Any advice or recommendation given by the Company or its employees or agents to the Buyer or its employees or agents as to the storage application or use of the Goods which is not confirmed in writing by the Company is followed or acted upon entirely at the Buyer's own risk and accordingly the Company shall not be liable for any such advice or recommendation which is not confirmed.

2.4 Any typographical clerical or other error or omission in any sales literature quotation price list acceptance of offer invoice or other document or information issued by the Company shall be subject to correction without any liability on the part of the Company.

2.5 All specifications, drawings, particulars of weight and dimension and performance data contained in any of the Company's literature are approximate only 2.6 The Company reserves the right to improve and/or modify any specifications, designs and drawings without notice.

2.7 For the avoidance of doubt nothing in these Conditions or any Contract shall confer on any third party any benefit nor the right to enforce any part of these Conditions or any Contract whether pursuant to the Contracts (Rights of Third Parties) Act 1999.

3. THE PRICE AND PAYMENT

3.1 The Price shall be either:

3.1.1 the Company's quotation price which shall only be valid for 30 days from its date after which time the Price may be altered by the Company and shall be subject to the Company's quotation; or

3.1.2 where no price has been quoted the Price listed in the then current price list of the Company sent by the Company to the Buyer at the time to time.

3.2 Except as otherwise stated in the Company's quotation or in any price list of the Company or otherwise agreed in writing between the Buyer and the Company, all prices are given by the Company to include the Company's charges for transport and insurance.

3.3 The Company shall be liable for any and other sums payable by the Buyer to the Company is exclusive of any applicable Value Added Tax, which the Buyer shall be additionally liable to pay to the Company.

3.4 Subject to any special terms agreed in writing between the Buyer and the Company, the Company may invoice the Buyer for all of the Goods sold to the Buyer, or any instalment of the Goods, unless the Goods are to be collected by the Buyer or the Buyer wrongfully fails to take delivery of the Goods, in which event the Buyer shall be entitled to invoice the Buyer for the Price at any time after the Company has notified the Buyer that the Goods are ready for collection or to take delivery of the Goods.

3.5 The Buyer shall be liable to pay the Price for the Goods, whether or not the Buyer has taken delivery of the Goods, in full at the time of the Price and VAT shall be due within the agreed period from the date of the invoice without deduction or set off. Time for payment shall be of the essence.

3.6 The Buyer shall be liable to make any payment on the due date then without prejudice to any other right or remedy available to the Company. The Buyer shall be entitled to: 3.6.1 cancel the Contract or suspend any further deliveries to the Buyer

3.6.2 appropriate any payment made by the Buyer to such of the Goods (or the Goods supplied under any other contract between the Buyer and the Company) as the Buyer may think fit (including the Goods to be delivered under the Contract) and

3.6.3 charge the Buyer interest (both before and after judgement) on the amount unpaid at the rate of 8% per cent per annum above Barclays Bank PLC base rate from time to time until payment in full is made (is a part of a month being treated as a full month for the purpose of calculating interest)

4. THE GOODS

4.1 The quantity and description of the Goods shall be as set out in the Company's quotation or in the Company's offer (as the case may be); and

4.2 The quantity and specification for the Goods shall be as set out in the Company's quotation or (where there is no quotation) in the Company's literature and brochure for the Goods in question.

4.3 The Buyer shall be responsible to the Company for ensuring the accuracy of the terms of any order and any information supplied to the Company as to its requirements (including but not limited to the use to which the Goods will be put and any applicable specification) submitted by the Buyer and for giving the Company any necessary information relating to the Goods within a sufficient time to enable the Company to perform the Contract in accordance with its terms 4.3.4 If the Goods are to be used for any other purpose than that specified by the Company, the Buyer shall be responsible for obtaining the approval of the Buyer. The Buyer shall indemnify the Company against all losses damages costs, claims, demands, liabilities and expenses awarded against or incurred by the Company in connection with and paid or agreed to be paid by the Company in settlement of any claim or infringement of any patent copyright design trade mark or industrial or intellectual property rights of any other person which results from the Company's use of the Buyer's specification or

from compliance by the Company with the Buyer's instructions whether express or implied.

4.4 No order which has been accepted by the Company may be cancelled by the Buyer except with the agreement in writing of the Company and on terms that any deposit paid shall not be repayable and that the Buyer shall indemnify the Company in full against all loss (including loss of profit) costs (including the cost of all labour and materials used) damages charges and expenses incurred by the Company in carrying out any work in respect of the Goods or otherwise as a result of cancellation.

4.5 All designs, sketches and articles supplied by or submitted in confidence to the Company shall remain the property of the Company and may not be disclosed by or not copied or otherwise reproduced by the Buyer without the prior written consent of the Company.

5. DELIVERY OF GOODS

5.1 Unless otherwise agreed in writing the Company shall deliver the Goods to such delivery address as is specified by the Buyer to the Company at such time as the Goods or part thereof (as the case may be) are ready for delivery.

5.2 The Buyer shall be responsible for loading the Goods at the delivery address. The Company may, at the option of the Company of any local law, bays or rules relating to parking or loading of vehicles at the delivery address.

5.3 The Buyer shall be responsible for ensuring that access to the delivery address is wholly by a road with a surface capable of withstanding the weight of the vehicles carrying the Goods.

5.4 Any dates quoted for delivery of the Goods are approximate only and the Company shall not be liable for any delay in delivery of the Goods whatsoever caused Time for delivery shall not be of the essence unless previously agreed.

5.5 In writing the Goods may be delivered by the Company in accordance with the Delivery Date upon giving reasonable notice to the Buyer

5.6 Where the Goods are to be delivered in instalments each delivery shall constitute a separate contract and failure by the Company to deliver any or more of the instalments, in accordance with these Conditions or any claim by the Buyer in respect of any one or more instalments, shall not entitle the Buyer to treat the Contract as a whole as repudiated.

5.6 If the Buyer fails for any reason whatsoever to take delivery of the Goods or fails to give the Company adequate delivery instructions, the time stated for delivery (whether by any reason any cause beyond the Buyer's reasonable control or by reason of the Company's fault) shall not apply to any other goods to be delivered by the Company.

5.6.1 The Goods shall actually deliver and charge the Buyer for the reasonable costs (including insurance) of returning the Goods to the Company's premises, storage and for transport, packaging and insurance for re-delivery of the Goods to the Buyer.

5.6.2 The Goods shall be delivered (after deduction of any storage and selling expenses) account to the Buyer for the excess over the Price or charge the Buyer for any shortfall below the Price

5.6.3 Goods may not be returned to the Company except by prior written permission of an authorised officer of the Company and the Goods shall be subject to payment by the Buyer of handling and re-stocking charges, transport and all other costs incurred by the Company

6. RISK AND RETENTION OF TITLE

6.1 Goods supplied by the Company shall be at the Buyer's risk immediately upon delivery to the Buyer or into custody on the Buyer's behalf or to the Buyer's Order. The Buyer shall effect adequate insurance of the goods against all risks to the full invoice value of the goods, such insurance to be effective from the time of delivery until payment in the goods shall pass to the Buyer as aforesaid.

6.2 Property in the goods supplied hereunder will pass to the Buyer when full payment has been made by the Buyer to the Company.

6.2.1 The Goods of the subject of this contract.

6.2.2 All other goods the subject of to any other contract between the Buyer and the Company which, at the time of payment of the full price of the goods sold under this contract, have been delivered to the Buyer but not paid for in full. 6.3 Until property in the goods supplied hereunder passes to the Buyer in accordance with paragraph (3) above.

6.3 The Buyer shall hold the goods in a fiduciary capacity for use and sale the same separately from any other goods in the Buyer's possession and in a manner which enables them to be identified as our goods.

6.3.2 The Buyer shall immediately return the goods to the Company should the Companies authorised representative so request. All necessary instructions for return of the goods to the Company shall apply.

6.4 The Buyer's right to possess the goods shall cease forthwith upon the happening of any of the following events, namely: -

6.4.1 If the Buyer fails to make payment in full for the goods within the time stipulated in clause 2 hereabove;

6.4.2 If the Buyer, not being a holder of a licence, makes, uses, or offers for sale or for hire or creditors for a compromise or does anything which would entitle a petition for a Bankruptcy Order to be presented;

6.4.3 If the Buyer, being a company, does anything or fails to do anything which would entitle an administrator or an administrator or a receiver or liquidator of any assets or which would entitle any person to present a petition for winding up or to apply for an administration order;

6.5 The Buyer hereby grants to the Company an irrevocable licence to enter at any time any vehicle or premises owned or occupied by the Buyer or in the possession of the Buyer for purposes of repossessing and recovering any such goods the property in which has remained in the Company under the Contract (2) above. The Company shall not be responsible for the Buyer indemnify the Company against liability in respect of damage caused to any vehicle or premises in such repossession and removal being damaged which was not reasonably practicable to avoid.

6.6 Notwithstanding paragraph 6.5 hereabove, the Buyer shall be permitted to sell the goods to third parties in the normal course of business. In this respect the Buyer shall act in the capacity of the Companies commission agent and the proceeds of such sale:

6.6.1 shall be held in trust for us in a manner which enables such proceeds to be identified as such, and;

6.6.2 shall not be mixed with other monies nor paid into an overdraft bank account. The Company, as principal, shall remunerate the Buyer as commission agent a commission depending upon the surplus which the Buyer can obtain over and above the sum,

stipulated in this contract of supply which will satisfy the Company.

6.7 In the event that the Buyer shall sell any of the goods pursuant to clause (5) hereover, the Buyer shall forthwith inform the Company in writing of such sale and of the identity and address of the third party to whom the goods have been sold. 6.8 If before paragraph (3) above the goods are sold or disposed of by the Buyer under paragraph (3) above the goods are to become affected to any land or building owned by the Buyer it is hereby agreed and declared that such affixation shall not have the effect of passing property in the goods to the Buyer. Furthermore if, before property in the goods shall pass to the Buyer under paragraph (3) hereover, the goods are or become affected to any land or building owned by the Buyer, the Buyer shall:

6.8.1 ensure that the goods are capable of being removed without material injury to such land or building;

6.8.2 take the necessary steps to prevent title to the goods from passing to the landlord of such land or building;

6.8.3 forthwith inform the Company in writing of such affixation and of the address of the land or building concerned. The Buyer warrants to repair and make good any damage caused by the affixation of the goods to or their removal from any land or building or to indemnify the Company accordingly. Paragraph (3) above the goods are to become affected to any land or building owned by the Buyer it is hereby agreed and declared that such affixation shall not have the effect of passing property in the goods to the Buyer. Furthermore if, before property in the goods shall pass to the Buyer under paragraph (3) hereover, the goods are or become affected to any land or building owned by the Buyer, the Buyer shall:

6.8.1 ensure that the goods are capable of being removed without material injury to such land or building;

6.8.2 take the necessary steps to prevent title to the goods from passing to the landlord of such land or building;

6.8.3 forthwith inform the Company in writing of such affixation and of the address of the land or building concerned. The Buyer warrants to repair and make good any damage caused by the affixation of the goods to or their removal from any land or building or to indemnify the Company accordingly. Paragraph (3) above the goods are to become affected to any land or building owned by the Buyer it is hereby agreed and declared that such affixation shall not have the effect of passing property in the goods to the Buyer. Furthermore if, before property in the goods shall pass to the Buyer under paragraph (3) hereover, the goods are or become affected to any land or building owned by the Buyer, the Buyer shall:

6.8.1 ensure that the goods are capable of being removed without material injury to such land or building;

6.8.2 take the necessary steps to prevent title to the goods from passing to the landlord of such land or building;

6.8.3 forthwith inform the Company in writing of such affixation and of the address of the land or building concerned. The Buyer warrants to repair and make good any damage caused by the affixation of the goods to or their removal from any land or building or to indemnify the Company accordingly. Paragraph (3) above the goods are to become affected to any land or building owned by the Buyer it is hereby agreed and declared that such affixation shall not have the effect of passing property in the goods to the Buyer. Furthermore if, before property in the goods shall pass to the Buyer under paragraph (3) hereover, the goods are or become affected to any land or building owned by the Buyer, the Buyer shall:

6.8.1 ensure that the goods are capable of being removed without material injury to such land or building;

6.8.2 take the necessary steps to prevent title to the goods from passing to the landlord of such land or building;

6.8.3 forthwith inform the Company in writing of such affixation and of the address of the land or building concerned. The Buyer warrants to repair and make good any damage caused by the affixation of the goods to or their removal from any land or building or to indemnify the Company accordingly. Paragraph (3) above the goods are to become affected to any land or building owned by the Buyer it is hereby agreed and declared that such affixation shall not have the effect of passing property in the goods to the Buyer. Furthermore if, before property in the goods shall pass to the Buyer under paragraph (3) hereover, the goods are or become affected to any land or building owned by the Buyer, the Buyer shall:

6.8.1 ensure that the goods are capable of being removed without material injury to such land or building;

6.8.2 take the necessary steps to prevent title to the goods from passing to the landlord of such land or building;

6.8.3 forthwith inform the Company in writing of such affixation and of the address of the land or building concerned. The Buyer warrants to repair and make good any damage caused by the affixation of the goods to or their removal from any land or building or to indemnify the Company accordingly. Paragraph (3) above the goods are to become affected to any land or building owned by the Buyer it is hereby agreed and declared that such affixation shall not have the effect of passing property in the goods to the Buyer. Furthermore if, before property in the goods shall pass to the Buyer under paragraph (3) hereover, the goods are or become affected to any land or building owned by the Buyer, the Buyer shall:

6.8.1 ensure that the goods are capable of being removed without material injury to such land or building;

6.8.2 take the necessary steps to prevent title to the goods from passing to the landlord of such land or building;

6.8.3 forthwith inform the Company in writing of such affixation and of the address of the land or building concerned. The Buyer warrants to repair and make good any damage caused by the affixation of the goods to or their removal from any land or building or to indemnify the Company accordingly. Paragraph (3) above the goods are to become affected to any land or building owned by the Buyer it is hereby agreed and declared that such affixation shall not have the effect of passing property in the goods to the Buyer. Furthermore if, before property in the goods shall pass to the Buyer under paragraph (3) hereover, the goods are or become affected to any land or building owned by the Buyer, the Buyer shall:

6.8.1 ensure that the goods are capable of being removed without material injury to such land or building;

6.8.2 take the necessary steps to prevent title to the goods from passing to the landlord of such land or building;

6.8.3 forthwith inform the Company in writing of such affixation and of the address of the land or building concerned. The Buyer warrants to repair and make good any damage caused by the affixation of the goods to or their removal from any land or building or to indemnify the Company accordingly. Paragraph (3) above the goods are to become affected to any land or building owned by the Buyer it is hereby agreed and declared that such affixation shall not have the effect of passing property in the goods to the Buyer. Furthermore if, before property in the goods shall pass to the Buyer under paragraph (3) hereover, the goods are or become affected to any land or building owned by the Buyer, the Buyer shall:

6.8.1 ensure that the goods are capable of being removed without material injury to such land or building;

6.8.2 take the necessary steps to prevent title to the goods from passing to the landlord of such land or building;

6.8.3 forthwith inform the Company in writing of such affixation and of the address of the land or building concerned. The Buyer warrants to repair and make good any damage caused by the affixation of the goods to or their removal from any land or building or to indemnify the Company accordingly. Paragraph (3) above the goods are to become affected to any land or building owned by the Buyer it is hereby agreed and declared that such affixation shall not have the effect of passing property in the goods to the Buyer. Furthermore if, before property in the goods shall pass to the Buyer under paragraph (3) hereover, the goods are or become affected to any land or building owned by the Buyer, the Buyer shall:

6.8.1 ensure that the goods are capable of being removed without material injury to such land or building;

6.8.2 take the necessary steps to prevent title to the goods from passing to the landlord of such land or building;

6.8.3 forthwith inform the Company in writing of such affixation and of the address of the land or building concerned. The Buyer warrants to repair and make good any damage caused by the affixation of the goods to or their removal from any land or building or to indemnify the Company accordingly. Paragraph (3) above the goods are to become affected to any land or building owned by the Buyer it is hereby agreed and declared that such affixation shall not have the effect of passing property in the goods to the Buyer. Furthermore if, before property in the goods shall pass to the Buyer under paragraph (3) hereover, the goods are or become affected to any land or building owned by the Buyer, the Buyer shall:

6.8.1 ensure that the goods are capable of being removed without material injury to such land or building;

6.8.2 take the necessary steps to prevent title to the goods from passing to the landlord of such land or building;

6.8.3 forthwith inform the Company in writing of such affixation and of the address of the land or building concerned. The Buyer warrants to repair and make good any damage caused by the affixation of the goods to or their removal from any land or building or to indemnify the Company accordingly. Paragraph (3) above the goods are to become affected to any land or building owned by the Buyer it is hereby agreed and declared that such affixation shall not have the effect of passing property in the goods to the Buyer. Furthermore if, before property in the goods shall pass to the Buyer under paragraph (3) hereover, the goods are or become affected to any land or building owned by the Buyer, the Buyer shall:

6.8.1 ensure that the goods are capable of being removed without material injury to such land or building;

6.8.2 take the necessary steps to prevent title to the goods from passing to the landlord of such land or building;

6.8.3 forthwith inform the Company in writing of such affixation and of the address of the land or building concerned. The Buyer warrants to repair and make good any damage caused by the affixation of the goods to or their removal from any land or building or to indemnify the Company accordingly. Paragraph (3) above the goods are to become affected to any land or building owned by the Buyer it is hereby agreed and declared that such affixation shall not have the effect of passing property in the goods to the Buyer. Furthermore if, before property in the goods shall pass to the Buyer under paragraph (3) hereover, the goods are or become affected to any land or building owned by the Buyer, the Buyer shall:

6.8.1 ensure that the goods are capable of being removed without material injury to such land or building;

6.8.2 take the necessary steps to prevent title to the goods from passing to the landlord of such land or building;

6.8.3 forthwith inform the Company in writing of such affixation and of the address of the land or building concerned. The Buyer warrants to repair and make good any damage caused by the affixation of the goods to or their removal from any land or building or to indemnify the Company accordingly. Paragraph (3) above the goods are to become affected to any land or building owned by the Buyer it is hereby agreed and declared that such affixation shall not have the effect of passing property in the goods to the Buyer. Furthermore if, before property in the goods shall pass to the Buyer under paragraph (3) hereover, the goods are or become affected to any land or building owned by the Buyer, the Buyer shall:

6.8.1 ensure that the goods are capable of being removed without material injury to such land or building;

6.8.2 take the necessary steps to prevent title to the goods from passing to the landlord of such land or building;

6.8.3 forthwith inform the Company in writing of such affixation and of the address of the land or building concerned. The Buyer warrants to repair and make good any damage caused by the affixation of the goods to or their removal from any land or building or to indemnify the Company accordingly. Paragraph (3) above the goods are to become affected to any land or building owned by the Buyer it is hereby agreed and declared that such affixation shall not have the effect of passing property in the goods to the Buyer. Furthermore if, before property in the goods shall pass to the Buyer under paragraph (3) hereover, the goods are or become affected to any land or building owned by the Buyer, the Buyer shall:

6.8.1 ensure that the goods are capable of being removed without material injury to such land or building;

6.8.2 take the necessary steps to prevent title to the goods from passing to the landlord of such land or building;

6.8.3 forthwith inform the Company in writing of such affixation and of the address of the land or building concerned. The Buyer warrants to repair and make good any damage caused by the affixation of the goods to or their removal from any land or building or to indemnify the Company accordingly. Paragraph (3) above the goods are to become affected to any land or building owned by the Buyer it is hereby agreed and declared that such affixation shall not have the effect of passing property in the goods to the Buyer. Furthermore if, before property in the goods shall pass to the Buyer under paragraph (3) hereover, the goods are or become affected to any land or building owned by the Buyer, the Buyer shall:

6.8.1 ensure that the goods are capable of being removed without material injury to such land or building;

6.8.2 take the necessary steps to prevent title to the goods from passing to the landlord of such land or building;

6.8.3 forthwith inform the Company in writing of such affixation and of the address of the land or building concerned. The Buyer warrants to repair and make good any damage caused by the affixation of the goods to or their removal from any land or building or to indemnify the Company accordingly. Paragraph (3) above the goods are to become affected to any land or building owned by the Buyer it is hereby agreed and declared that such affixation shall not have the effect of passing property in the goods to the Buyer. Furthermore if, before property in the goods shall pass to the Buyer under paragraph (3) hereover, the goods are or become affected to any land or building owned by the Buyer, the Buyer shall:

6.8.1 ensure that the goods are capable of being removed without material injury to such land or building;

6.8.2 take the necessary steps to prevent title to the goods from passing to the landlord of such land or building;

6.8.3 forthwith inform the Company in writing of such affixation and of the address of the land or building concerned. The Buyer warrants to repair and make good any damage caused by the affixation of the goods to or their removal from any land or building or to indemnify the Company accordingly. Paragraph (3) above the goods are to become affected to any land or building owned by the Buyer it is hereby agreed and declared that such affixation shall not have the effect of passing property in the goods to the Buyer. Furthermore if, before property in the goods shall pass to the Buyer under paragraph (3) hereover, the goods are or become affected to any land or building owned by the Buyer, the Buyer shall:

6.8.1 ensure that the goods are capable of being removed without material injury to such land or building;

6.8.2 take the necessary steps to prevent title to the goods from passing to the landlord of such land or building;

6.8.3 forthwith inform the Company in writing of such affixation and of the address of the land or building concerned. The Buyer warrants to repair and make good any damage caused by the affixation of the goods to or their removal from any land or building or to indemnify the Company accordingly. Paragraph (3) above the goods are to become affected to any land or building owned by the Buyer it is hereby agreed and declared that such affixation shall not have the effect of passing property in the goods to the Buyer. Furthermore if, before property in the goods shall pass to the Buyer under paragraph (3) hereover, the goods are or become affected to any land or building owned by the Buyer, the Buyer shall:

6.8.1 ensure that the goods are capable of being removed without material injury to such land or building;

6.8.2 take the necessary steps to prevent title to the goods from passing to the landlord of such land or building;

6.8.3 forthwith inform the Company in writing of such affixation and of the address of the land or building concerned. The Buyer warrants to repair and make good any damage caused by the affixation of the goods to or their removal from any land or building or to indemnify the Company accordingly. Paragraph (3) above the goods are to become affected to any land or building owned by the Buyer it is hereby agreed and declared that such affixation shall not have the effect of passing property in the goods to the Buyer. Furthermore if, before property in the goods shall pass to the Buyer under paragraph (3) hereover, the goods are or become affected to any land or building owned by the Buyer, the Buyer shall:

6.8.1 ensure that the goods are capable of being removed without material injury to such land or building;

6.8.2 take the necessary steps to prevent title to the goods from passing to the landlord of such land or building;

6.8.3 forthwith inform the Company in writing of such affixation and of the address of the land or building concerned. The Buyer warrants to repair and make good any damage caused by the affixation of the goods to or their removal from any land or building or to indemnify the Company accordingly. Paragraph (3) above the goods are to become affected to any land or building owned by the Buyer it is hereby agreed and declared that such affixation shall not have the effect of passing property in the goods to the Buyer. Furthermore if, before property in the goods shall pass to the Buyer under paragraph (3) hereover, the goods are or become affected to any land or building owned by the Buyer, the Buyer shall:

6.8.1 ensure that the goods are capable of being removed without material injury to such land or building;

6.8.2 take the necessary steps to prevent title to the goods from passing to the landlord of such land or building;

6.8.3 forthwith inform the Company in writing of such affixation and of the address of the land or building concerned. The Buyer warrants to repair and make good any damage caused by the affixation of the goods to or their removal from any land or building or to indemnify the Company accordingly. Paragraph (3) above the goods are to become affected to any land or building owned by the Buyer it is hereby agreed and declared that such affixation shall not have the effect of passing property in the goods to the Buyer. Furthermore if, before property in the goods shall pass to the Buyer under paragraph (3) hereover, the goods are or become affected to any land or building owned by the Buyer, the Buyer shall:

6.8.1 ensure that the goods are capable of being removed without material injury to such land or building;

6.8.2 take the necessary steps to prevent title to the goods from passing to the landlord of such land or building;

6.8.3 forthwith inform the Company in writing of such affixation and of the address of the land or building concerned. The Buyer warrants to repair and make good any damage caused by the affixation of the goods to or their removal from any land or building or to indemnify the Company accordingly. Paragraph (3) above the goods are to become affected to any land or building owned by the Buyer it is hereby agreed and declared that such affixation shall not have the effect of passing property in the goods to the Buyer. Furthermore if, before property in the goods shall pass to the Buyer under paragraph (3) hereover, the goods are or become affected to any land or building owned by the Buyer, the Buyer shall:

6.8.1 ensure that the goods are capable of being removed without material injury to such land or building;

6.8.2 take the necessary steps to prevent title to the goods from passing to the landlord of such land or building;

6.8.3 forthwith inform the Company in writing of such affixation and of the address of the land or building concerned. The Buyer warrants to repair and make good any damage caused by the affixation of the goods to or their removal from any land or building or to indemnify the Company accordingly. Paragraph (3) above the goods are to become affected to any land or building owned by the Buyer it is hereby agreed and declared that such affixation shall not have the effect of passing property in the goods to the Buyer. Furthermore if, before property in the goods shall pass to the Buyer under paragraph (3) hereover, the goods are or become affected to any land or building owned by the Buyer, the Buyer shall:

6.8.1 ensure that the goods are capable of being removed without material injury to such land or building;

6.8.2 take the necessary steps to prevent title to the goods from passing to the landlord of such land or building;

6.8.3 forthwith inform the Company in writing of such affixation and of the address of the land or building concerned. The Buyer warrants to repair and make good any damage caused by the affixation of the goods to or their removal from any land or building or to indemnify the Company accordingly. Paragraph (3) above the goods are to become affected to any land or building owned by the Buyer it is hereby agreed and declared that such affixation shall not have the effect of passing property in the goods to the Buyer. Furthermore if, before property in the goods shall pass to the Buyer under paragraph (3) hereover, the goods are or become affected to any land or building owned by the Buyer, the Buyer shall:

6.8.1 ensure that the goods are capable of being removed without material injury to such land or building;

6.8.2 take the necessary steps to prevent title to the goods from passing to the landlord of such land or building;

6.8.3 forthwith inform the Company in writing of such affixation and of the address of the land or building concerned. The Buyer warrants to repair and make good any damage caused by the affixation of the goods to or their removal from any land or building or to indemnify the Company accordingly. Paragraph (3) above the goods are to become affected to any land or building owned by the Buyer it is hereby agreed and declared that such affixation shall not have the effect of passing property in the goods to the Buyer. Furthermore if, before property in the goods shall pass to the Buyer under paragraph (3) hereover, the goods are or become affected to any land or building owned by the Buyer, the Buyer shall:

6.8.1 ensure that the goods are capable of being removed without material injury to such land or building;

6.8.2 take the necessary steps to prevent title to the goods from passing to the landlord of such land or building;

6.8.3 forthwith inform the Company in writing of such affixation and of the address of the land or building concerned. The Buyer warrants to repair and make good any damage caused by the affixation of the goods to or their removal from any land or building or to indemnify the Company accordingly. Paragraph (3) above the goods are to become affected to any land or building owned by the Buyer it is hereby agreed and declared that such affixation shall not have the effect of passing property in the goods to the Buyer. Furthermore if, before property in the goods shall pass to the Buyer under paragraph (3) hereover, the goods are or become affected to any land or building owned by the Buyer, the Buyer shall:

6.8.1 ensure that the goods are capable of being removed without material injury to such land or building;

6.8.2 take the necessary steps to prevent title to the goods from passing to the landlord of such land or building;

6.8.3 forthwith inform the Company in writing of such affixation and of the address of the land or building concerned. The Buyer warrants to repair and make good any damage caused by the affixation of the goods to or their removal from any land or building or to indemnify the Company accordingly. Paragraph (3) above the goods are to become affected to any land or building owned by the Buyer it is hereby agreed and declared that such affixation shall not have the effect of passing property in the goods to the Buyer. Furthermore if, before property in the goods shall pass to the Buyer under paragraph (3) hereover, the goods are or become affected to any land or building owned by the Buyer, the Buyer shall:

UK Cylinders

Unit 3, RCM Business Centre, Sandbeds Trading Estate,
Dewsbury Road, Ossett, WF5 9ND
Tel: **03330 329 650** Email: **sales@ukcylinders.co.uk**