

SERVICE | AVAILABILITY | QUALITY | PERFORMANCE | RELIABILITY

# FlowCyl & FlowCyl AIR

Unvented Cylinders Product Guide



UK CYLINDERS

YOUR HOT WATER SPECIALISTS





# UK Cylinders

## Your Hot Water Specialists

UK Cylinders is a UK-based manufacturer of unvented hot water cylinder solutions for traditional and renewable energy systems, supplying social housing providers, housebuilders, merchants and installers throughout the UK.

Operating three manufacturing facilities in Yorkshire, we combine scale, engineering expertise and controlled production processes to deliver consistent quality and dependable supply.

All products are manufactured under a certified ISO 9001 quality management system, ensuring structured process control, traceability and continuous improvement across the business.

**ENGINEERED FOR PERFORMANCE. MANUFACTURED FOR RELIABILITY. SUPPORTED NATIONWIDE.**

SERVICE | AVAILABILITY | QUALITY | PERFORMANCE | RELIABILITY

# Contents

About UK Cylinders	4
FlowCyl Standard	6
Trade Friendly Design	7
FlowCyl Slimline	10
FlowCyl Heat Pump, Solar PV Priority and Buffers	13
FlowCyl Horizontal	14
FlowCyl Air Standard	16
FlowCyl Air Slimline	19
Installation Guidance	21
Design Service	22



Your Hot Water Specialists  
Tel 03330 329 650





## Product Range

At UK Cylinders we pride ourselves on employing highly skilled engineers to produce a wide range of products suitable for all of our customer needs. Our FlowCyl products are manufactured to the highest quality, with the best raw materials and ancillary components in many different specifications.

If you can't find the cylinder you need in our product guide then please speak to your local representative or our sales office as we can produce bespoke products if required.

Our products come with a manufacturer's guarantee (see details in product guide) and are fully tested to ensure they are compliant with the latest standards and regulations.



## Manufacturing Process & Scale

UK Cylinders operates three UK manufacturing facilities in Yorkshire, providing distributed production capability, operational resilience, and scalable capacity.

Our manufacturing structure supports social housing providers, housebuilders, merchants and installers. Each facility operates under a unified ISO 9001 certified quality management system, ensuring consistent standards and controlled processes across all product ranges.

Defined site specialisms provide focused expertise while maintaining group-wide operational flexibility. This enhances continuity of supply, flexible production planning and reliable delivery across volume housing and project-led developments.

We invest in modern fabrication equipment, controlled production environments, and skilled local engineers. Key processes are carried out in-house, enabling tighter quality control and improved lead-time management.

Active capacity planning supports current demand and future growth, with production capability scalable to over 100,000 cylinders per annum.



## Performance & Reliability

UK Cylinders products are designed to deliver consistent hot water performance across a wide range of domestic and commercial applications.

Through disciplined design, proven materials and controlled manufacturing processes, our cylinders offer reliable operation, fast recovery and long service life. This focus on performance and repeatability helps minimise installation issues and reduces ongoing maintenance for installers and end users alike.





## Quality and Service

Customer service is at the forefront of everything we do. From product selection and specification support through to order fulfilment and aftersales assistance, our teams work closely with merchants, installers and partners to ensure a smooth and reliable experience.

We respond promptly to enquiries and provide clear, practical support when it is needed, helping to minimise delays, reduce site issues and keep projects moving. Our aim is to deliver consistent service standards that match the quality and reliability of our products.

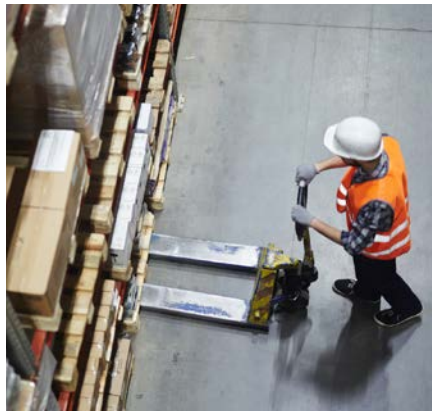

## Availability and Stockists

We carry significant stock across our UK warehouses, alongside inventory held with our merchant partners.

Orders for stock items placed before 12 midday are despatched the same day.

We work closely with our network of merchant stockists, supporting them in delivering reliable hot water solutions to their customers.

For details of your local stockist, please contact us on **03330 329 650** or [sales@ukcylinders.co.uk](mailto:sales@ukcylinders.co.uk)



## Environmental - and a more sustainable future

Our environmental management processes focus on the efficient manufacture of products, the responsible use of materials and the reduction of waste across our operations.

Through structured procedures and continuous review of our manufacturing activities, UK Cylinders works to minimise environmental impact while maintaining product quality, reliability and long-term performance.

Please contact us on **03330 329 650**  
or [sales@ukcylinders.co.uk](mailto:sales@ukcylinders.co.uk)



# FlowCyl

## Designed for performance and reliability

The FlowCyl sets the standard for unvented cylinders, manufactured to the highest quality in our UK factory by the best manufacturing specialists.

We manufacture our cylinders in the UK using high quality Duplex stainless steel, this enables us to provide a 25-year warranty. Each cylinder is supplied with market leading components to give peace of mind for years to come. The FlowCyl provides fast flowing water to all outlets and even in high use situations it is designed to reheat quickly with its superior performance and low heat loss.

### SPECIFICATION

- > Supplied with a manufacturer's backed 25 year cylinder warranty and 2 years parts warranty.
- > Diameter is 545mm from capacities 90L to 300L.
- > Manufactured from high grade Duplex Stainless Steel.
- > Fully insulated with 50mm 100% CFC and HCFC free polyurethane to minimise heat loss.
- > Lightweight construction with high quality and **100% recyclable** silver casing.
- > Supplied with high quality unvented components.
- > Supplied with a mechanical cylinder stat for simple electrical installation.
- > All plumbing connections are clearly identified with their description embossed into the cylinder case.
- > 22mm compression connections complete with nuts and olives on the 90ltr-300ltr and 28mm connections on the 400-600ltr.
- > Market leading and highly efficient primary coil which reduces reheat time and saves fuel bills.
- > Long-life 3kW Incoloy immersion heater supplied as standard.
- > Immersion heater upgrades available upon request - i.e. Titanium or 6kW.
- > Supplied with all safety controls as required by UK Building Regulations.



# Trade Friendly Design

## Complete ease of installation

All UK **Cylinders** products are designed to ensure a problem free installation for our valued trade customers. We design our products for ease of installation and handling so they can be sited almost anywhere in the building. Please see the table below which lists all the supplied components provided with our vast range of cylinder solutions.

COMPONENT	DIRECT	INDIRECT	SINGLE COIL SOLAR	TWIN COIL SOLAR
INLET CONTROL SET	•	•	•	•
TWO PORT VALVE		•		•
DUAL THERMOSTAT		•		
SINGLE HIGH LIMIT STAT			•	•
IMMERSION HEATER(S)	•	•	•	•
T&P RELIEF VALVE	•	•	•	•
T&P VALVE INSULATION COVER	•	•	•	•
*EXPANSION VESSEL	•	•	•	•
TUNDISH	•	•	•	•
INSTALLATION/ USER MANUAL	•	•	•	•

The FlowCyl comes complete with all the fittings you will need for a complete trouble free installation.

\*Expansion vessel not supplied/required with FlowCyl Air models.

## Expansion Vessel Sizing Guide

CYLINDER CAPACITY (L)	12	18	24	35	50
60 to 150	•				
170 to 250		•			
300			•		
400			•		
500				•	
600					•



COLD WATER INLET SET



TWO PORT ZONE VALVE



DUAL THERMOSTAT



3KW IMMERSION HEATER



T&P RELIEF VALVE



EXPANSION VESSEL



TUNDISH



T&P VALVE INSULATED COVER



ENERGY CUT-OUT THERMOSTAT





## FlowCyl Direct Unvented

Description	Product Code	Nominal Capacity (L)	Weight (KG)	Weight full (KG)	Height (mm)	Diameter (mm)	Immersion heater(s)	Standing Heat Loss		ERP BAND
								kWh/ 24h	WATTS	
90 L	FCDIR0090	90	19	109	747	545	1	1.01	42	C
120 L	FCDIR0120	120	23	143	945	545	2	1.06	44	C
150 L	FCDIR0150	150	26	176	1130	545	2	1.22	51	C
180 L	FCDIR0180	180	30	200	1314	545	2	1.40	56	C
200 L	FCDIR0200	200	34	234	1444	545	2	1.44	60	C
250 L	FCDIR0250	250	37	287	1752	545	2	1.75	73	C
300 L	FCDIR0300	300	43	343	1975	545	2	2.04	85	C

## FlowCyl Indirect Unvented

Description	Product Code	Nominal Capacity (L)	Weight (KG)	Weight full (KG)	Height (mm)	Diameter (mm)	Coil Rating KW	Reheat Time (mins)	Immersion heater(s)	Standing Heat Loss		ERP BAND
										kWh/ 24h	WATTS	
90 L	FCIND0090	90	22	112	747	545	15.89	14	1	1.01	42	B
120 L	FCIND0120	120	25	145	945	545	17.76	17	1	1.06	44	B
150 L	FCIND0150	150	28	178	1130	545	18.25	21	1	1.22	51	B
180 L	FCIND0180	180	32	202	1314	545	19.35	27	1	1.40	58	B
200 L	FCIND0200	200	35	235	1444	545	19.94	31	1	1.44	60	B
250 L	FCIND0250	250	41	391	1752	545	20.68	36	1	1.75	73	C
300 L	FCIND0300	300	45	345	1975	545	23.57	41	1	2.04	85	C
400 L	FCIND0400	400	76	476	1640	690	27.58	45	2	2.20	92	C
500 L	FCIND0500	500	92	592	1995	690	28.49	56	2	2.42	101	C
600 L	FCIND0600	545	103	703	2190	690	29.90	68	2	2.68	112	C



## FlowCyl Single Coil Solar Unvented

Description	Product Code	Nominal Capacity (L)	Weight (KG)	Weight full (KG)	Height (mm)	Diameter (mm)	Coil Rating KW	Immersion heater(s)	Standing Heat Loss		ERP BAND
									kWh/ 24h	WATTS	
150 L	FCSDI0150	150	28	178	1130	545	17.8	2	1.22	51	B
180 L	FCSDI0180	180	32	202	1314	545	18.76	2	1.40	56	B
200 L	FCSDI0200	200	35	235	1444	545	19.65	2	1.44	60	B
250 L	FCSDI0250	250	42	292	1752	545	21.24	2	1.75	73	C
300 L	FCSDI0300	300	46	346	1975	545	17.8	2	2.04	85	C

## FlowCyl Twin Coil Solar Unvented

Description	Product Code	Nominal Capacity (L)	Weight (KG)	Weight full (KG)	Height (mm)	Diameter (mm)	Coil Rating KW	Reheat Time (mins)	Immersion heater(s)	Standing Heat Loss		ERP BAND
										kWh/ 24h	WATTS	
150 L	FCSIN0150	150	30	180	1130	545	16.8/ 16.8	16	1	1.22	51	B
180 L	FCSIN0180	180	34	204	1314	545	17.8/ 17.87	18	1	1.40	56	B
200 L	FCSIN0200	200	37	237	1444	545	18.76/ 18.48	21	1	1.44	60	B
250 L	FCSIN0250	250	45	295	1752	545	19.65/ 19.21	24	1	1.75	73	C
300 L	FCSIN0300	300	49	349	1975	545	21.24/ 20.16	27	1	2.04	85	C



# FlowCyl Slimline

When installation space is at a premium, we offer the same great product but with a much smaller footprint.

The FlowCyl Slimline is manufactured to the same high standards as all other FlowCyls but at 475mm diameter to fit in smaller applications or to fit through narrow cylinder cupboard doors. The FlowCyl Slimline is also supplied with a 25-year warranty and with high quality components for peace of mind.

## SPECIFICATION

- > Supplied with a manufacturer's backed 25 year cylinder warranty and 2 years parts warranty.
- > Diameter is 475mm from capacities 60L to 200L.
- > Manufactured from high grade Duplex Stainless Steel.
- > Fully insulated with 50mm 100% CFC and HCFC free polyurethane to minimise heat loss.
- > Lightweight construction with high quality and **100% recyclable** silver casing.
- > Supplied with high quality unvented components.
- > Supplied with a mechanical cylinder stat for simple electrical installation.
- > All plumbing connections are clearly identified with their description embossed into the cylinder case.
- > 22mm compression connections complete with nuts and olives.
- > Market leading and highly efficient primary coil which reduces reheat time and saves fuel bills.
- > Long-life 3kW Incoloy immersion heater supplied as standard.
- > Immersion heater upgrades available upon request - i.e. Titanium or 6kW.
- > Supplied with all safety controls as required by UK Building Regulations.





## FlowCyl Slimline Direct Unvented

Description	Product Code	Nominal Capacity (L)	Weight (KG)	Weight full (KG)	Height (mm)	Diameter (mm)	Immersion heater(s)	Standing Heat Loss		ERP BAND
								kWh/ 24h	WATTS	
60L	FCNDI0060	60	17	77	744	475	1	0.94	39	C
90L	FCNDI0090	90	19	109	1007	475	2	1.06	44	C
120L	FCNDI0120	120	23	143	1270	475	2	1.25	52	C
150L	FCNDI0150	150	27	177	1535	475	2	1.42	59	C
170L	FCNDI0170	170	31	201	1710	475	2	1.51	63	C
200L	FCNDI0200	200	35	235	1980	475	2	1.58	66	C

## FlowCyl Slimline Indirect Unvented

Description	Product Code	Nominal Capacity (L)	Weight (KG)	Weight full (KG)	Height (mm)	Diameter (mm)	Coil Rating KW	Reheat Time (mins)	Immersion heater(s)	Standing Heat Loss		ERP BAND
										kWh/ 24h	WATTS	
60L	FCNIN0060	60	19	79	744	475	14.62	15	1	0.94	39	B
90L	FCNIN0090	90	21	111	1007	475	15.17	16	1	1.06	44	B
120L	FCNIN0120	120	25	145	1270	475	18.76	19	1	1.25	52	B
150L	FCNIN0150	150	29	179	1535	475	18.82	21	1	1.42	59	C
170L	FCNIN0170	170	33	203	1710	475	19.22	24	1	1.51	63	C
200L	FCNIN0200	200	37	237	1980	475	19.36	29	1	1.58	66	C





## FlowCyl Single Coil Solar Slimline Unvented

Description	Product Code	Nominal Capacity (L)	Weight (KG)	Weight full (KG)	Height (mm)	Diameter (mm)	Coil Rating KW	Immersion heater(s)	Standing Heat Loss		ERP BAND
									kWh/ 24h	WATTS	
150 L	FCSSD0150	150	38	188	1535	475	18.25	2	1.42	59	C
170 L	FCSSD0170	170	42	212	1710	475	19.35	2	1.51	63	C
200 L	FCSSD0200	200	45	245	1980	475	19.94	2	1.58	66	C

## FlowCyl Twin Coil Solar Slimline Unvented

Description	Product Code	Nominal Capacity (L)	Weight (KG)	Weight full (KG)	Height (mm)	Diameter (mm)	Coil Rating KW	Reheat Time (mins)	Immersion heater(s)	Standing Heat Loss		ERP BAND
										kWh/ 24h	WATTS	
150L	FCSSI0150	150	40	190	1535	475	18.25/18.76	14	1	1.42	59	C
170L	FCSSI0170	170	45	215	1710	475	19.35/19.22	17	1	1.51	63	C
200L	FCSSI0200	200	48	248	1980	475	19.94/19.36	21	1	1.58	66	C

# Looking for our Universally Compatible Heat Pump Cylinders, PV Ready Cylinders and Buffers?



We have an extensive product range of Low Carbon system solutions suitable for Air Source and Ground Source including:

- > Universally Compatible Heat Pump Cylinders 120-600L
- > Slimline and Combined Buffer Integrated Options
- > Pre-Plumbed Heat Pump Cylinders
- > Horizontal Heat Pump Cylinders
- > Solar PV Priority Cylinders
- > Buffers 50 - 600L



Scan the QR code to see our specialist Heat Pump brochure

The UK's Widest Range of Heat Pump, PV and Buffer Cylinder Solutions

# FlowCyl Horizontal

Designed with performance in mind.

The FlowCyl Horizontal is designed for use in applications where a vertical cylinder will not fit, typically in a loft space. In dwellings that require all the benefits of a mains pressure cylinder, but you have limitations on space, the FlowCyl Horizontal is the product for you.

The FlowCyl Horizontal is supplied with installation cradles, high quality components and a 25-year warranty for peace of mind.



## SPECIFICATION

- > Supplied with a manufacturer's backed 25 year cylinder warranty and 2 years parts warranty.
- > Diameter is 545mm from capacities 120L to 300L.
- > Manufactured from high grade Duplex Stainless Steel.
- > Fully insulated with 50mm 100% CFC and HCFC free polyurethane to minimise heat loss.
- > Lightweight construction with high quality and **100% recyclable** silver casing.
- > Supplied with high quality unvented components and mounting cradles.
- > Supplied with a mechanical cylinder stat for simple electrical installation.
- > All plumbing connections are clearly identified with their description embossed into the cylinder case.
- > 22mm compression connections complete with nuts and olives.
- > Market leading and highly efficient primary coil which reduces reheat time and saves fuel bills.
- > Long-life 3kW Incoloy immersion heater supplied as standard.
- > Immersion heater upgrades available upon request - i.e. Titanium or 6kW.
- > Supplied with all safety controls as required by UK Building Regulations.

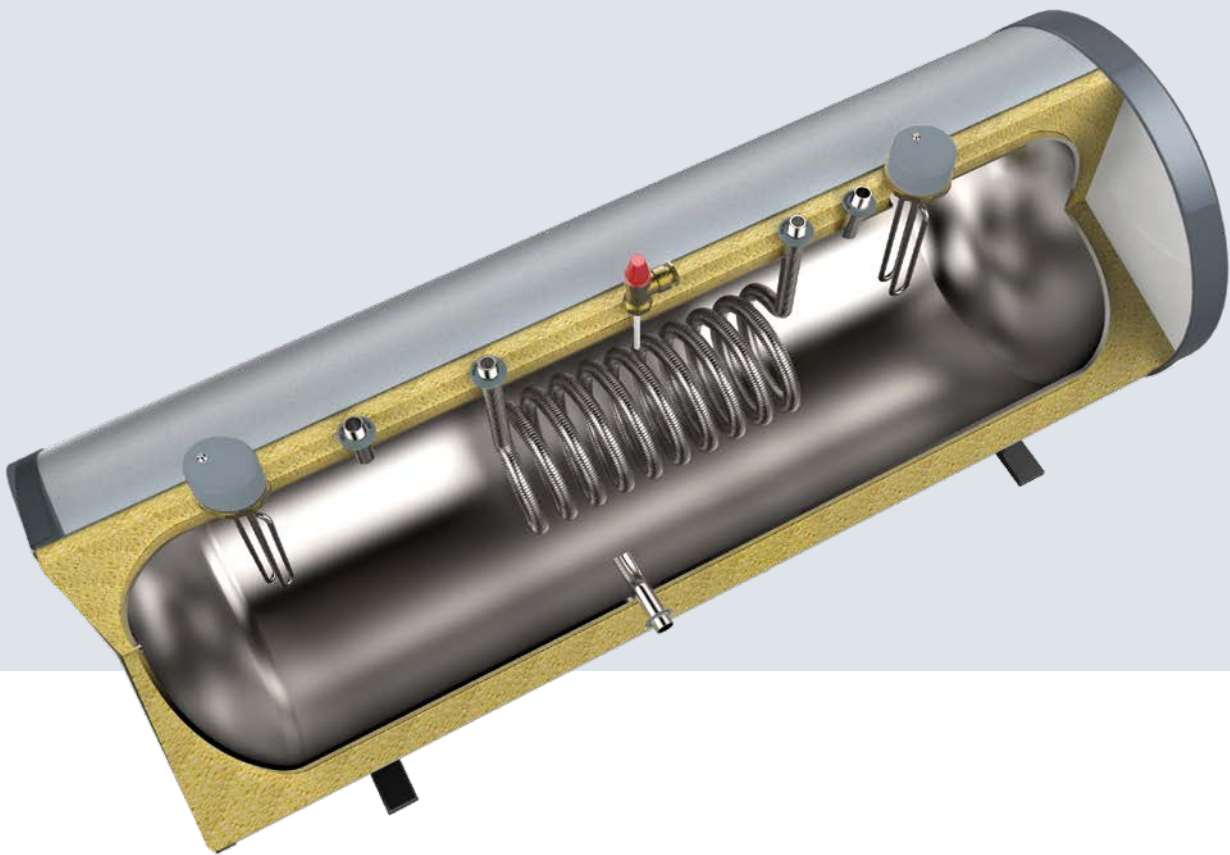

## FlowCyl Horizontal Indirect Unvented

Description	Product Code	Nominal Capacity (L)	Weight (KG)	Weight full (KG)	Width (mm)	Diameter (mm)	Coil Rating KW	Reheat Time (mins)	Immersion heater(s)	Standing Heat Loss		ERP BAND
										kWh/24h	WATTS	
120L	FCHOI0120	120	27	147	945	545	15.8	17	1	1.30	54	C
150L	FCHOI0150	150	33	183	1130	545	16.5	22	2	1.56	65	C
180L	FCHOI0180	180	38	208	1314	545	18	22	2	1.65	69	C
200L	FCHOI0200	200	40	240	1444	545	19.94	25	2	1.87	78	C
250L	FCHOI0250	250	46	296	1752	545	20.68	28	2	2.11	88	C
300L	FCHOI0300	300	50	350	1975	545	23.57	32	2	2.30	96	C



# FlowCyl Air Standard

The first choice internal expansion unvented cylinder.  
Designed for performance and reliability.

Our range of superior quality FlowCyl AIR cylinders are built using high grade Duplex stainless steel and designed to provide fast flowing hot water to single or multiple outlets. Manufactured to the highest standards and supplied with innovative components to ensure quick recovery, low heat loss and economic use of energy.

For your peace of mind the cylinders carry a 25 year cylinder and 2 year parts guarantee, making them an excellent choice for your hot water system.

## SPECIFICATION

- > Internal expansion cylinder for faster installation and saving space.
- > Supplied with a manufacturer's backed 25 year cylinder warranty and 2 years parts warranty.
- > Diameter is 545mm from capacities 120L to 300L.
- > Manufactured from high grade Duplex Stainless Steel.
- > Fully insulated with 50mm 100% CFC and HCFC free polyurethane to minimise heat loss.
- > Lightweight construction with high quality and **100% recyclable** silver casing.
- > Supplied with high quality unvented components.
- > Supplied with a mechanical cylinder stat for simple electrical installation.
- > All plumbing connections are clearly identified with their description embossed into the cylinder case.
- > 22mm compression connections complete with nuts and olives.
- > Market leading and highly efficient primary coil which reduces reheat time and saves fuel bills.
- > Long-life 3kW Incoloy immersion heater supplied as standard.
- > Immersion heater upgrades available upon request - i.e. Titanium or 6kW.
- > Supplied with all safety controls as required by UK Building Regulations.





## FlowCyl Air Direct Invented

Description	Product Code	Nominal Capacity (L)	Weight (KG)	Weight full (KG)	Height (mm)	Diameter (mm)	Immersion heater(s)	Standing Heat Loss		Secondary Return Included as standard	ERP BAND
								kWh/ 24h	WATTS		
120L	FADIR0120	120	26	133	945	545	2	1.01	42	✗	C
150L	FADIR0150	150	33	171	1130	545	2	1.20	50	✗	C
180L	FADIR0180	180	38	197	1314	545	2	1.33	54	✗	C
200L	FADIR0200	200	41	225	1444	545	2	1.39	58	✓	C
250L	FADIR0250	250	46	281	1752	545	2	1.44	60	✓	C
300L	FADIR0300	300	55	319	1975	545	2	1.80	75	✓	C

## FlowCyl Air Indirect Invented

Description	Product Code	Nominal Capacity (L)	Weight (KG)	Weight full (KG)	Height (mm)	Diameter (mm)	Coil Rating KW	Reheat Time (mins)	Immersion heater(s)	Standing Heat Loss		Secondary Return Included as standard	ERP BAND
										kWh/ 24h	WATTS		
120L	FAIND0120	120	30	135	945	545	15.89	15	1	1.01	42	✗	B
150L	FAIND0150	150	38	172	1130	545	17.76	18	1	1.20	50	✗	B
180L	FAIND0180	180	42	197	1314	545	18.25	22	1	1.33	54	✗	B
200L	FAIND0200	200	45	222	1444	545	19.35	26	1	1.39	58	✓	B
250L	FAIND0250	250	51	281	1752	545	19.94	29	1	1.44	60	✓	B
300L	FAIND0300	300	60	319	1975	545	20.68	35	1	1.80	75	✓	C





## FlowCyl Air Solar Single Coil Indirect Unvented

Description	Product Code	Nominal Capacity (L)	Weight (KG)	Weight full (KG)	Height (mm)	Diameter (mm)	Coil Rating KW	Immersion heater(s)	Standing Heat Loss		Secondary Return Included as standard	ERP BAND
									kWh/ 24h	WATTS		
180L	FACDI0180	180	42	197	1314	545	17.8	2	1.33	54	✗	B
200L	FACDI0200	200	45	222	1444	545	18.76	2	1.39	58	✓	B
250L	FACDI0250	250	51	281	1752	545	19.65	2	1.44	60	✓	B
300L	FACDI0300	300	60	319	1975	545	21.24	2	1.80	75	✓	C

## FlowCyl Air Solar Twin Coil Indirect Unvented

Description	Product Code	Nominal Capacity (L)	Weight (KG)	Weight full (KG)	Height (mm)	Diameter (mm)	Coil Rating KW	Reheat Time (mins)	Immersion heater(s)	Standing Heat Loss		Secondary Return Included as standard	ERP BAND
										kWh/ 24h	WATTS		
180L	FACIN0180	180	42	193	1314	545	17.8/17.87	16	1	1.33	54	✗	B
200L	FACIN0200	200	48	222	1444	545	18.76/18.48	19	1	1.39	58	✓	B
250L	FACIN0250	250	53	279	1752	545	19.65/19.21	23	1	1.44	60	✓	B
300L	FACIN0300	300	63	317	1975	545	21.24/20.16	27	1	1.80	75	✓	C

# FlowCyl Air Slimline

We also have a slimline version of the FlowCyl AIR for use when space is at a premium. At only 475mm width the FlowCyl AIR Slimline can be utilised in smaller cylinder cupboards or when access routes are smaller, often in older dwellings. The FlowCyl AIR Slimline also has a 25-year manufacturer's warranty.

## SPECIFICATION

- > Internal expansion cylinder for faster installation and saving space.
- > Supplied with a manufacturer's backed 25 year cylinder warranty and 2 years parts warranty.
- > Diameter is 475mm from capacities 120L to 200L.
- > Manufactured from high grade Duplex Stainless Steel.
- > Fully insulated with 50mm 100% CFC and HCFC free polyurethane to minimise heat loss.
- > Lightweight construction with high quality and **100% recyclable** silver casing.
- > Supplied with high quality unvented components.
- > Supplied with a mechanical cylinder stat for simple electrical installation.
- > All plumbing connections are clearly identified with their description embossed into the cylinder case.
- > 22mm compression connections complete with nuts and olives.
- > Market leading and highly efficient primary coil which reduces reheat time and saves fuel bills.
- > Long-life 3kW Incoloy immersion heater supplied as standard.
- > Immersion heater upgrades available upon request - i.e. Titanium or 6kW.
- > Supplied with all safety controls as required by UK Building Regulations.





## FlowCyl Air Direct Slimline

Description	Product Code	Nominal Capacity (L)	Weight (KG)	Weight full (KG)	Height (mm)	Diameter (mm)	Immersion heater(s)	Standing Heat Loss		ERP BAND	ERP Efficiency	ERP Profile
								kWh/ 24h	WATTS			
120L	FANDI0120	120	26	133	1270	475	2	1.15	48	C	36	M
150L	FANDI0150	150	33	164	1535	475	2	1.37	57	C	36	M
170L	FANDI0170	170	38	187	1710	475	2	1.49	62	C	34	M
200L	FANDI0200	200	41	222	1980	475	2	1.61	67	C	37	L

## FlowCyl Air Indirect Slimline

Description	Product Code	Nominal Capacity (L)	Weight (KG)	Weight full (KG)	Height (mm)	Diameter (mm)	Coil Rating KW	Reheat Time (mins)	Immersion heater(s)	Standing Heat Loss		Secondary Return Included as standard	ERP BAND
										kWh/ 24h	WATTS		
120L	FANIN0120	120	30	134	1270	475	18.76	15	1	1.15	48	✗	B
150L	FANIN0150	150	38	166	1535	475	18.82	17	1	1.37	57	✗	C
170L	FANIN0170	170	42	188	1710	475	19.22	20	1	1.49	62	✗	C
200L	FANIN0200	200	45	215	1980	475	19.36	27	1	1.61	67	✓	C

# Installation Guidance



For full details on product installation, please refer to the installation guide supplied with all cylinders, or downloadable from our website [www.ukcylinders.co.uk](http://www.ukcylinders.co.uk)

## Selection Guide

Choosing the right cylinder for your needs

HOT WATER DEMAND	BEDROOMS	INDIRECT	DIRECT
1 Standard Bath or Shower	Bedsit / 1	120	120
	2-3	120	150
	3-4	150	150
1 Standard Bath	2-3	150	180
	3-4	150	180
1 Standard Bath and En-Suite	2-3	180	200
	3-4	180	200
	4-5	180	200
2 Standard Baths	2-3	180	250
	3-4	180	250
	4-5	200	300
3 Bathrooms	3-4	250	300
	4-5	300	300
	5-6	300	300

## Customer Care

### Continued support

All **UK Cylinders** unvented products come with a manufacturer's warranty so if you have a breakdown or fault, we are on hand to provide customer support to put it right.

Please contact our team on 03330 329 650 or email [customercare@ukcylinders.co.uk](mailto:customercare@ukcylinders.co.uk) and we will be there ready to help you.

## Trade Friendly Design and Installation

### Regulations

Please refer to Section G3 of the Building Regulations (England and Wales), Technical Standard P3 (Scotland) and Building Regulations P5 (Northern Ireland). All Unvented units with a capacity over 15 litres must be installed by a competent installer in accordance with these regulations.

### Mains Supply

**UK Cylinders** unvented cylinder FlowCyl require a minimum of 1.5 bar (max 10 bar) mains pressure and 20 litres per minute flow rate to ensure that the cylinder meets its minimum capabilities. Higher mains pressure and flow rates can return a higher performance from the cylinder.

**Note:** Cylinder must be connected to a mains water supply, not a well or borehole.

### Cylinder Siting

**UK Cylinders** range of unvented cylinders can be sited almost anywhere in a dwelling, particularly with the wide range of products we supply, providing hot water to outlets above and below the cylinder.

### Wiring

All electrical wiring should be fitted in accordance of the control scheme being used and by a competent electrician and the latest IEE regulations. **UK Cylinders** provide controls with all unvented cylinders to ensure the safe operation of the unit within a central heating system.

Please refer to the installation guide for full details.

### Boiler Compatibility

The FlowCyl cylinders are compatible with all appliances that are fitted with an integral control thermostat and its own energy cut-out (these include natural gas, lpg, electric and oil boilers).

Heat sources without full thermostatic control (Aga etc) cannot usually be installed with an unvented unit. Please consult the installation guide for comprehensive information.

### Secondary Return Connection

As standard a secondary connection is fitted on indirect models of 200 litres and above.



# REDD

RENEWABLE ENERGY DOMESTIC DESIGNS

Plumbing, Heating  
and Renewable energy  
design services for the  
new build industry

REDD provide designs for all types of heating, plumbing and renewable energy systems. These designs can incorporate natural gas, low pressure gas (LPG), electric or oil-fired boilers, air source heat pumps (ASHP) or ground source heat pumps (GSHP) – Plus whatever Building regulations, SAP calculations or the client requires.

Email your design enquiry to  
[designs@reddesign.uk](mailto:designs@reddesign.uk)



Renewable Energy Domestic Designs (REDD) core business is to provide a free-of-charge heating & plumbing design service to the new build housing sector. This is a 100% independent design company, able to provide designs for the domestic new build market incorporating any number of gas, electric or renewable energy based options.



Unit A | Washington Court | Windmill Avenue  
Kettering | Northants | NN16 0UE

T 01536 850350

E [designs@reddesign.uk](mailto:designs@reddesign.uk)

W [www.reddesign.uk](http://www.reddesign.uk)





# UK CYLINDERS

YOUR HOT WATER SPECIALISTS



UK CYLINDERS • UNIT 3 RCM BUSINESS CENTRE  
DEWSBURY ROAD • OSSETT • WEST YORKSHIRE • WF5 9ND

T 03330 329 650 • F 01924 977 079  
sales@ukcylinders.co.uk • [www.ukcylinders.co.uk](http://www.ukcylinders.co.uk)



UK Cylinders Ltd are proud to be members of the Hot Water Association (HWA) and are committed to its ethics and values

UK Cylinders endeavour to keep the content of this brochure as up-to-date as possible. We reserve the right to make changes to all UK Cylinders products and services at anytime. To ensure you have the most current information please contact UK Cylinders directly.