

# UK CYLINDERS

YOUR HOT WATER SPECIALISTS



## Indirect

### INSTALLATION MANUAL V1 SEP 2024

#### INDIRECT UNVENTED HOT WATER STORAGE CYLINDER WITH **EXTERNAL** EXPANSION VESSEL

Boiler - Indirect Single Coil, Indirect Solar Single Coil, Indirect Solar Twin Coil

#### IMPORTANT

This range of water heaters and unvented water storage cylinders should only be installed as per these instructions by a competent & certified heating installer. By installing this product you agree to be bound by the purchasing and warranty terms and conditions found in this manual and on our website.

#### Safe Disposal and WEEE Declaration

This cylinder is manufactured from and supplied with a variety of components made from recyclable materials. At the end of its working life, a hot water cylinder should be disposed of at a Local Authority Recycling Centre.

The Waste Electrical and Electronic Equipment (WEEE) directive makes use of the wheellie bin symbol, which indicates that this product must not be disposed of with regular household waste. Instead all products with this symbol must be disposed of at a designated point for the recycling of waste electrical equipment.

For more information about where you can drop off your WEEE please contact your household waste disposal service or the point of purchase for any of your electrical goods.



## INTRODUCTION

This UK manufactured product is made from Duplex stainless steel, providing durability and long-lasting resistance against corrosion. It is highly insulated with environmentally friendly foam, and enclosed in a rust resistant outer steel case.

The Indirect is an indirectly heated unvented hot water storage cylinder as defined under the current ErP Directive and available in eight sizes from 60-300litres.

The cylinder is approved to comply with G3 Building Regulations and the United Kingdom Water Supply (Water Fittings) Regulations / Scottish Water Byelaws.

This Indirect cylinder comes supplied with all necessary safety & control devices needed to connect to the water mains. If for any reason you suspect this may not be the case, please contact us (see back page).

**Please ensure that you have understood this manual before starting the installation, and leave this guide with the end user once the installation is complete.**

**For information on potential Warranty Exclusions – please see the appendix of this installation manual.**

## BENCHMARK

The Benchmark scheme places responsibilities on both manufacturers and installers. The purpose is to ensure that customers are provided with the correct equipment for their needs, that it is installed, commissioned and serviced in accordance with the manufacturer's instructions by competent persons and that it meets the requirements of the appropriate Building Regulations and relevant electrical qualifications. The Benchmark Checklist can be used to demonstrate compliance with Building Regulations and should be provided to the customer for future reference.

Installers are required to carry out installation, commissioning and servicing work in accordance with the Benchmark Code of Practice which is available from the Heating and Hotwater Industry Council who manage and promote the scheme.

Visit [www.centralheating.co.uk](http://www.centralheating.co.uk) for more information.

## COMPONENT LISTING

Cold Water Inlet Set	LOOSE
15 x 22mm Tundish	LOOSE
Temperature & Pressure Relief Valve	FITTED
Expansion Vessel & Mounting Bracket	LOOSE
Immersion Heater(s) - Capacity and configuration dependant	FITTED
Installation Manual	LOOSE
Benchmark Logbook - Found at the back of this manual	LOOSE

In addition, 2-Port zone valves and dual cylinder stats are provided with standard indirect cylinders, and high limit stats (as well as solar fixing grommets) are provided with solar single and twin coil cylinders.

## GENERAL INSTALLATION REQUIREMENTS

The cylinder must be installed, commissioned and maintained by a competent installer holding a current G3 unvented qualification, and/or being a member of a competent persons' scheme. Once the unit is installed and commissioned, the user must be given an explanation of the operation of the cylinder and its key safety components. In addition, the end user must be given this installation manual for future reference.

## STORAGE AND HANDLING

Care must be taken when handling the product. Seek assistance when moving the product as required, and follow safe working practices and lifting techniques to avoid injury or product damage. Before installation, the cylinder must be stored upright in its original packaging, on a secure, level surface within a dry and frost-free environment.

## SITING THE UNIT

This product must be installed vertically on a flat base that is capable of supporting the maximum-fill weight of the cylinder. For each metre an outlet is above the cylinder, the supply pressure of the hot water will be reduced by 0.1 bar.

The minimum recommended cupboard size is 650mm square as the product diameter can vary (capacity and configuration dependant) between 475mm to 580mm. This is to ensure that there is access to the cylinder safety controls/immersion heaters and for future valve maintenance or replacement during service. Therefore, please ensure all connections are outward facing towards a door or similar opening for this purpose.

Areas subject to freezing should be avoided. If the cylinder is sited outside of a heated area of the dwelling, such as a garage or outbuilding, ensure the provision of adequate frost protection, such as insulation of exposed pipework. Pipe lengths must be kept to a minimum to ensure minimal losses.

## COLD WATER INLET CONTROL SET

Included in your unvented safety components is a multibloc inlet control group. This single unit is standard issue for many unvented water systems, and comprises of many different safety valves, housed into a single brass casting. This is detailed as follows:

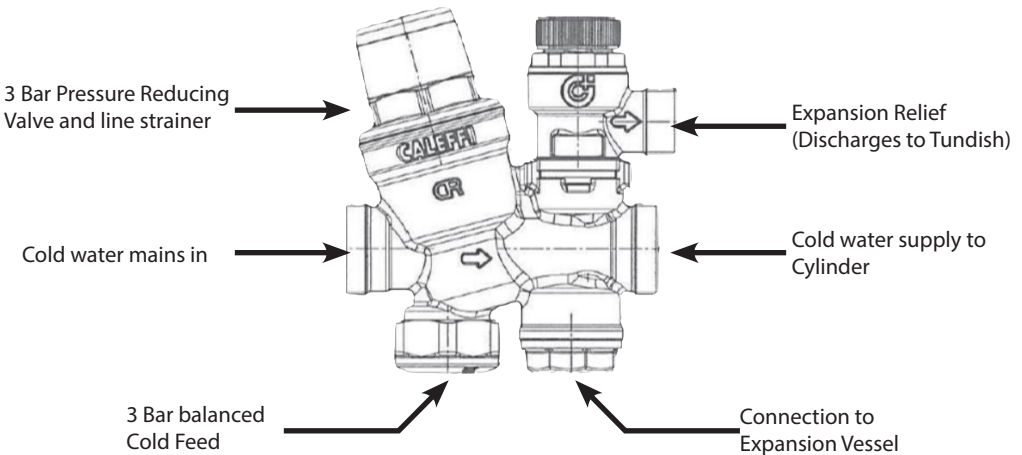

## WATER SUPPLY

We recommend that the maximum on-site water demand be assessed and the water supply be tested to ensure it meets the following requirements. This should be sourced from mains water only - your warranty does NOT include the use of wells or bore holes as a water supply.

It must be noted that a high mains water pressure does NOT always guarantee a high flow rate. Ensure a working (not static) condition site pressure reading is taken. The minimum mains water supply requirements should be 0.15MPa (1.5 bar) working pressure, and a 20 litres per minute flow rate available. Where mains inlet pressures may exceed 10 bar, an additional upstream pressure reducing device should be fitted in addition to the cold water inlet set provided.

The mains supply pipe-work should be a minimum of 22mm. This could warrant the replacement of any existing 1/2" (15mm) cold mains pipe-work.

The water supply must be of a wholesome water quality, defined as Fluid Category 1 in the Water Supply Regulations 1999. In areas of hard water content ( $\text{CaCO}_3$ ) greater than 200ppm, treatment should be installed.

## CHANGE OF WATER SUPPLY

The changing or alternation of one water supply to another can be detrimental on the operation and/or life expectation of the product and its accessories. Where a water supply changeover occurs, e.g. a rainwater tank supply, bore water supply, desalinated water supply, public reticulated water supply or water brought in from another supply, then water chemistry information should be sought, or should be tested to ensure the supply will meet the requirements given in these guidelines for our manufacturer's warranty to apply.

# CYLINDER SUPPLY AND SAFETY DISCHARGE SCHEMATIC

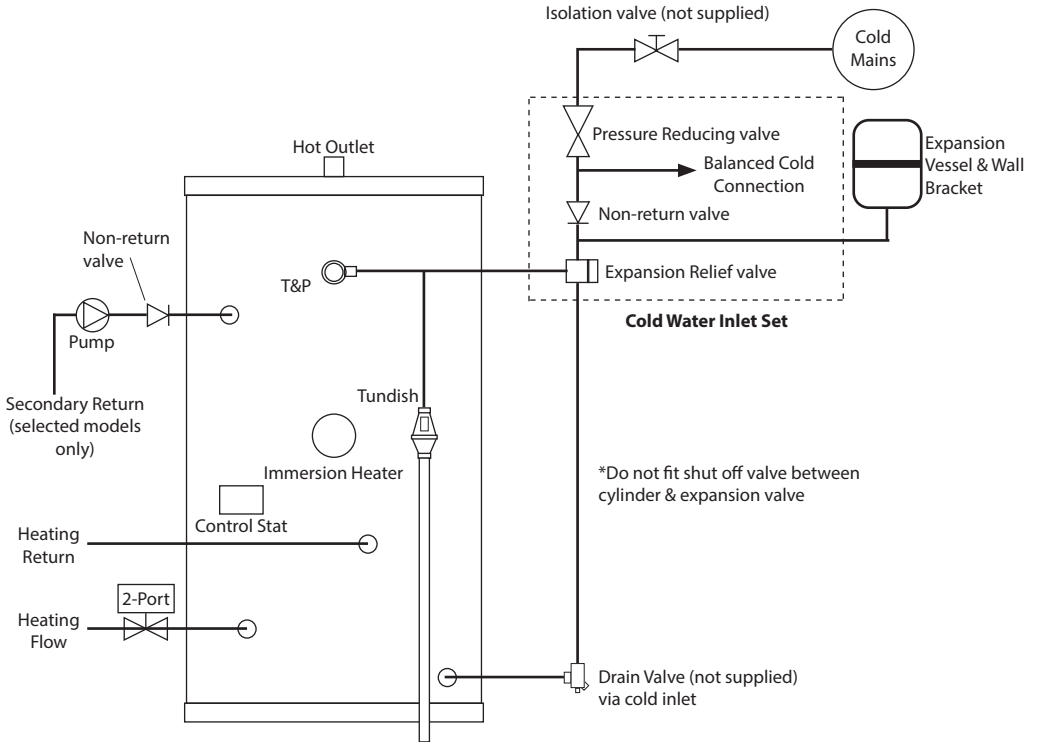

## GENERAL INSTALLATION AND COMMISSIONING

**PLEASE NOTE - THE WATER CONNECTION BOSSES AND THE OLIVES & GLAND NUTS SUPPLIED AS STANDARD ON THIS INDIRECT ARE THREADED 3/4" BSP.**

### COLD MAINS PIPEWORK

The cold mains pipework should be a minimum of 22mm, through to the cylinder installation to ensure that hot water flow requirements for taps and shower heads are met. Care should be taken to avoid inefficiency and heat transfer where cold water pipes run adjacent to hot water or heating pipework. Install an isolating valve (not supplied) to the cold mains pipework. A 22mm BS1010 stopcock or a quarter turn full-bore lever valve should be used rather than a screwdriver slot or other similar valve. Make the connection to the cold feed of the cylinder, incorporating a drain valve.

Position the inlet control set above the Temperature and Pressure Relief Valve (T&P) found on the side of the cylinder. This ensures the cylinder does not need to be drained in order to service the inlet control. Ensure the directional flow arrow on the inlet control follows the flow of water.

Mount the external expansion vessel in a suitable position to the wall using the provided bracket, and connect the pipework to the expansion vessel connection provided on the cold water inlet set. There must be no obstruction or flow restriction between the cylinder and the expansion vessel.

You must ensure that the cylinder does not fill to a pressure of greater than 3.0bar. If there are to be any showers, bidets, or monobloc taps in the installation (or wherever mixing/blending water fittings are installed) then a balanced cold supply is necessary, otherwise there is the danger of a mains fed cold service pressure leaking into the controlled hot circuit. Such back pressure would be detrimental to the system and could cause the unwarranted operation of discharge valves.

It is essential that the cold service be balanced throughout the property by taking the cold services from the **balanced cold connection** on the inlet control set. Should this not be possible an independent 3.0bar inlet

pressure reducing valve must be installed into the cold supply of any such mixed fitting, suitably positioned so as to not compromise water flow to the cylinder. An outside hose tap may still be connected direct to the incoming cold supply if desired.

## **HOT WATER PIPEWORK**

The majority of the hot water distribution pipework should be 22mm, possibly reduced to 15mm or 10mm dependant on the type of tap. Keep the hot draw off pipework to a minimum to maximise the transfer speed of hot water from cylinder to outlet. We advise against soldering fittings immediately to the hot water draw off, as this reduces any inherent risk of flux landing on the immersion heater and causing premature corrosion to the connection and unit.

If the balanced cold connection is not provided, do not use monobloc mixer taps or showers. This would cause the unit to back pressurise and result in discharge. Ensure that the top of the vessel is accessible for servicing.

## **CONNECTION OF PRIMARY COILS - BOILER AND SOLAR (See Schematic on Page 8)**

Both boiler and solar coils are provided with 22mm compression connections and are suitable for open vented or sealed system primary circuits. The coil must be positively pumped and are not suitable for gravity systems. To ensure maximum performance and efficiency the primary flow must enter the left hand lower coil connection when viewed from the front of the cylinder, and return from the right hand upper coil connection. An air release valve must be installed adjacent to the return connection point. The boiler coil should also benefit from the operation bypass when the heating circuit closes. See diagram.

In twin coil installations this installation detail applies to both coils.

The coils are rated to 6.0 bar maximum operating pressure although heating circuits normally operate at a maximum of 3.0 bar, solar circuits 6.0 bar. In a boiler circuit the two port valve should be installed in the primary flow. In a solar circuit the two port valve should be installed in the primary return.

Ensure an inhibitor suitable for use with stainless steel is used. Only connect the cylinder to a protected heat source with effective thermostatic control - uncontrolled heat sources such as solid fuel stoves, AGAs etc. may not be suitable - if in doubt seek guidance from ourselves.

## **CONTROL THERMOSTAT**

The non-solar indirect cylinders come provided with a mechanical control dual cylinder thermostat. This adjustable safety component can be changed by the end user to keep the hot water in the cylinder stored at any value between 25°C-65°C. As well as being a thermostatic control, the stat also functions as a heat source isolation safety device with the included 2-port zone valve in the event of overheating, and should be installed as per the wiring diagrams set out in this manual.

When the cylinder thermostat is set to maximum, please ensure that the flow output from the boiler is also set appropriately so that the vessel can achieve the desired temperature.

## **RECOMMENDED STORAGE TEMPERATURE**

For domestic usage a temperature set of 55°C-60°C is the norm. This is above recognised bacterial growth levels and low enough to prevent nuisance tripping of limit thermostats or unnecessary scaling.

## **SOLAR COIL INSTALLATION**

### **INDIRECT SOLAR SINGLE AND TWIN COIL MODELS**

Indirect solar single coil cylinders have one coil at the bottom of the cylinder for connection to the solar thermal system. For indirect solar twin coil cylinders connect only the lower coil to the solar thermal system. Connection procedure to solar is identical for both products. Connect the solar coil as instructed in the above section "CONNECTION OF PRIMARY COILS - BOILER AND SOLAR". The solar temperature control sensor (supplied as part of the solar package) inserts into the pocket directly above the coil and is retained with the wiring grommet supplied. High limit control of the solar input is monitored with the single high limit thermostat which inserts into an upper pocket at the same height as the T&P relief valve. For installations where solar panels are higher than the cylinder connect the stat to interrupt the electrical supply from the solar pump and / or solar control panel. For installations where the solar panels are lower than the cylinder connect the high limit thermostat to close a two-port valve (not supplied) installed on the solar return pipework. With solar indirect twin coil the upper coil connects to the boiler flow and return. The dual control / high limit thermostat installs into the pocket immediately above the upper coil and is wired to activate the two-port valve (supplied) installed into the boiler primary flow.

This cylinder as supplied is not designed for installation with two boilers without extra controls listed below. Should it be the desire to connect the solar indirect twin coil cylinder to two boilers then a further dual control / high limit thermostat and two port-valve will be required and both coils and safety controls must be installed as per the single coil boiler format. Both the additional thermostat and two port valve may be purchased from the cylinder manufacturer.

## **SECONDARY CIRCULATION**

Secondary return connections are supplied as standard on 200-300 litre indirect cylinders only. Where secondary circulation is unavoidable for smaller capacity cylinders, a circulator suitable for potable water must be used in conjunction with a non-return valve to prevent backflow. The return connection should be made with a swept tee into the cold feed pipework directly above the drain connection. It may be necessary to incorporate an extra expansion vessel into the circuit to accommodate an increased system volume in larger secondary circulation systems.

## **IMMERSION HEATER**

All standard supply is with immersion heater elements of 3 Kilowatt output at 240 Volts, Incoloy elements, double pole thermal isolation and a 1¾" BSP threaded head.

### **ELECTRICAL CONNECTION - 3kW**

This appliance must be earthed. It is suitable for a 240 volt A.C. supply only. The electrical installation should only be carried out by a suitably qualified electrician in accordance with latest I.E.E. regulations. Ensure the electrical supply is isolated before working on the system.

The electrical supply to each immersion heater must be fused at 13A via a double pole isolating switch with a separation of at least 3mm to both poles to BS 3456.

The cable must be 2.5mm<sup>2</sup> heat resistant (85°C HOFR) sheathed flex complying to BS EN 50525. Do not use a cable of lesser rating.

For immersion heaters other than 3kW consult wiring requirements supplied with the immersion heater.

Do not operate the immersion heater(s) until the unit is full of water. If any sterilisation liquid is in the cylinder do not operate the immersion heater(s) as this will cause premature failure.

This device must be earthed.

Earth connection, (green & yellow), should be made firmly to the earth post marked "E", using the terminal attachments provided. Live connection, (brown), from the mains supply cable to the thermostat terminal marked "L". Neutral connection, (blue), from the mains supply cable to the thermostat terminal marked "N".

### **WIRING - 3kW**

Our 3kW immersion heaters MUST be wired in 2.5mm<sup>2</sup> heat resistant cable, as failure to do so can cause nuisance tripping. We will be unable to support your installation until this has been corrected. For alternate higher wattage immersion heaters, consult the instructions supplied with the device.

### **COMMERCIAL/HEAVY DUTY USE**

For commercial/heavy duty installations with constant usage/reheat requirements or where an external programmer designed for immersion heaters is not present then Titanium immersion heaters must be fitted in order to comply with the warranty.

### **RECOMMENDED TEMPERATURE SETTINGS - IMMERSION HEATER**

For domestic usage a temperature set of 55°C-60°C is the norm. This is above the growth temperature area for Legionella and low enough to prevent nuisance tripping and unnecessary scaling.

### **THERMOSTAT OPERATION**

The thermostat has an adjustable control operating between 20°C and 65°C. The usual desired domestic setting is between 55°C and 60°C. The thermostat is supplied set at 60°C. For setting the stat, turn fully clockwise to the maximum, and then anticlockwise (back off) approximately a quarter of its travel. Then make minor adjustments to suit your personal taste.

### **THERMAL CUTOUT**

If the cylinder begins to overheat (80°C), the thermal cut-out will activate, isolating both the live and negative connections within the immersion heater. This may also happen during a power spike. For resetting, isolate the power supply and allow the cylinder to cool down. Remove the head cap and press the high limit cut-out reset button on top of the thermostat. Should nuisance tripping occur, consult a qualified electrician to investigate the power supply and/or the thermostat itself.

## REPLACEMENT IMMERSION HEATERS - ALL TYPES

Replacement immersion heaters are available in all formats for your water heater. These should be obtained via ourselves to ensure the correct specification is supplied, and our warranty is not compromised. The standard heater has incoloy elements, a 1 3/4" BSP threaded head and standard rating of 3kW at 240 volts. Check the label detail on the head before ordering, as alternative specifications are available.

The 'O' ring on the head of the immersion heater should be correctly positioned and lubricated with a WRAS approved silicon lubricant before fitting. Screw in by hand until almost sealed and then gently finish tightening as the 'O' rings will seal easily. Remake the wiring connection as per instructions provided.

## INSULATION OF THE TEMPERATURE & PRESSURE RELIEF VALVE

Components for insulating the T&P are supplied in order to retain heat and energy. Installation instructions are provided with the insulation cover.

## DISCHARGE ARRANGEMENT

**The diagram opposite was taken directly from UK government Building Regulations Part G: 2016.**

**This information is not exhaustive. If in doubt, seek advice. Full details of Building Regulation G3, is available from: [www.planningportal.gov.uk](http://www.planningportal.gov.uk)**

The discharge from both the temperature, and expansion relief valves can be joined together via a 15mm end feed tee. Water should only be discharged when there is a fault with the system, and be visible at the tundish. (Consider a safety device to alert those of impaired vision or mobility when this occurs.)

Discharge water must not be allowed to collect in the pipe-work but rather flow freely to the tundish. This should be vertically mounted, in a visible location, in the same space as the cylinder, and fitted as close as possible within 600mm of the safety device (the relief valves). The discharge pipework must be in accordance with Part G3 of the Building Regulations. These are as follows:

- The discharge pipe (D2) from the Tundish should have a vertical section of pipe 300mm long below the Tundish before any elbows or bends in the pipework.
- This pipe should then be installed with a continuous fall of at least 1 in 200 thereafter.
- The pipe must be at least one pipe size larger than the nominal outlet size of the safety device (unless its total equivalent hydraulic resistance exceeds that of a straight pipe 9m long i.e. discharge pipes between 9m and 18m equivalent resistance length should be at least two sizes larger than the nominal outlet size of the safety device, between 18 and 27m at least 3 times larger and so on.) Bends must be taken into account in calculating the flow resistance. An alternative approach for sizing discharge pipes would be to follow the BS 8558 Specification for the design installation, testing and maintenance of services supplying water for domestic use within buildings and their curtilages.

Discharge pipework should terminate in a safe place where there is no danger to persons in the vicinity of the discharge. Examples of acceptable discharge arrangements include:

- To a trapped gully with the outlet below a fixed grating and above a water seal.
- Downward discharges to low level, within 100mm, above external surfaces such as a car park, hard standing, grassed area with a protective wire cage to prevent contact but retaining visibility of discharge.
- Into a metal hopper at high level with a metal downpipe and a clearly visible termination point or onto a roof capable of withstanding high temperature discharge at least 3m away from any plastic guttering.

Building Regulation G3 allows non-metallic pipework within the tundish discharge (D2). The discharge pipe (D2) should be made of a) metal or b) another material that has demonstrated it can safely withstand high temperature water discharges and is clearly and permanently marked to identify the product and the performance standard. The discharge should not be connected to a soil discharge stack unless it can be demonstrated of safely withstanding high temperature water discharges, in which case it should;

1. Contain a mechanical seal, not a water trap, which allows water into the branch pipe but not foul drain air to be ventilated through the tundish.
2. Be a separate branch pipe with no sanitary appliances connected to it.
3. Plastic pipes used as branch pipes with the discharge should be Polybutalene (PB) or cross linked polythene (PEX) complying with national standards such as Class S of B7291-2: or Class S of BS7291-3 respectively.
4. Be continuously marked with a warning that no sanitary appliances should be connected to the pipe.
5. Plastic pipes should be joined and assembled with fittings appropriate to the circumstances in which they are used as set out in BS EN ISO 1043-1.

Queries regarding specific discharge arrangements should be directed to your local building control office.

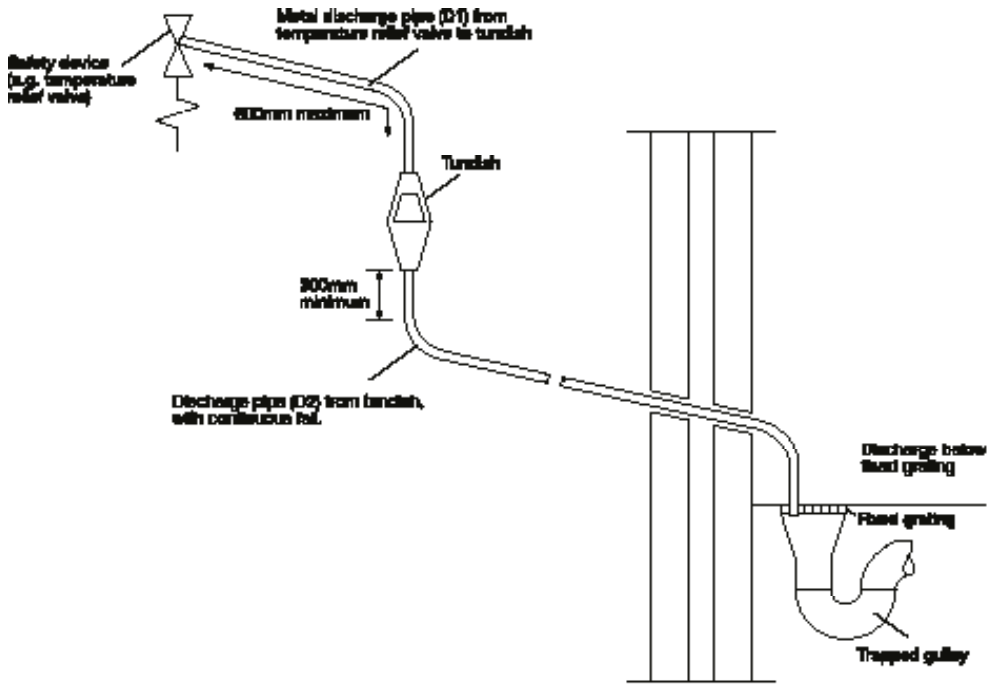

**SCHEMATIC OF COIL CONNECTION - TYPICAL 'S' PLAN**

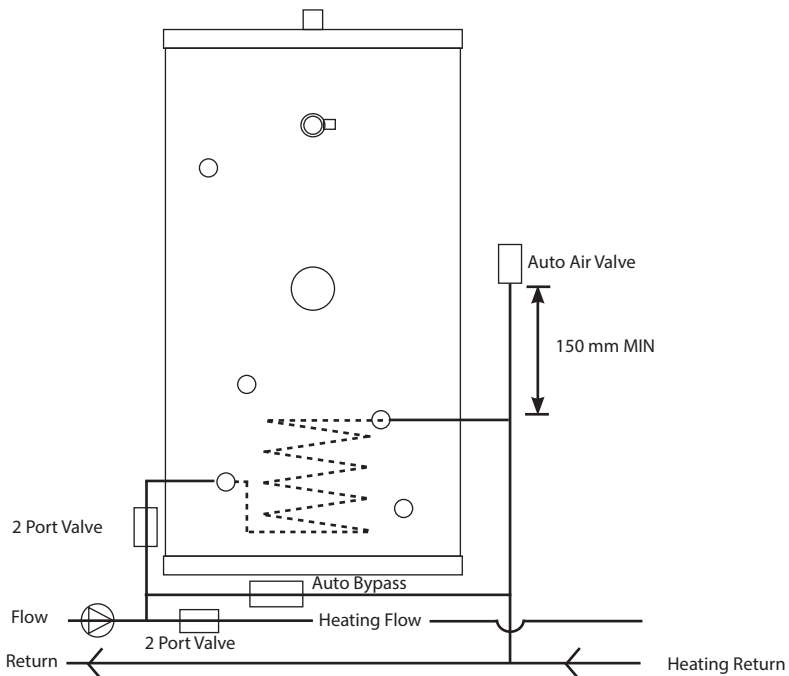

## TYPICAL WIRING - S PLAN, SINGLE ZONE

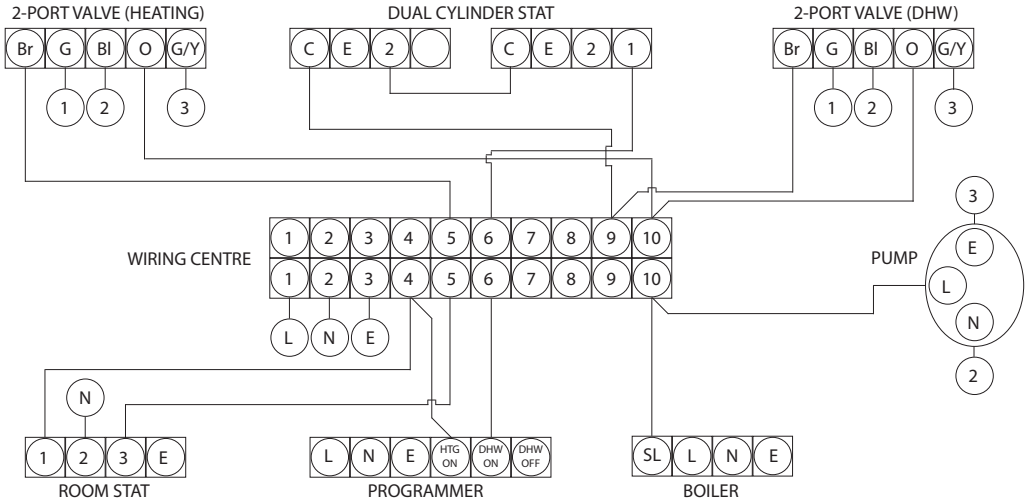

## TYPICAL WIRING - Y PLAN

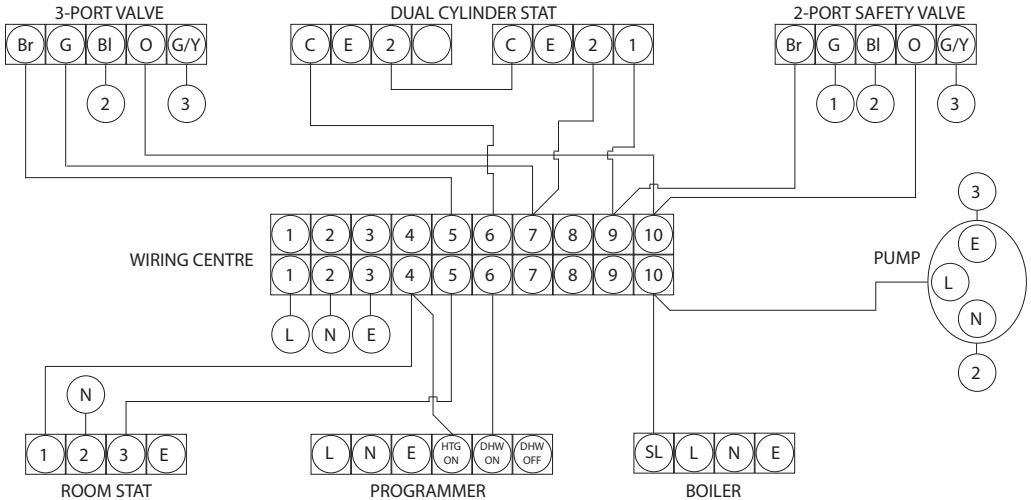

## COLOUR CODES

**W** = WHITE   **G** = GREEN   **Bl** = BLUE   **G/Y** = GREEN/YELLOW   **Br** = BROWN  
**L** = LIVE   **N** = NEUTRAL   **C** = COMMON   **SL** = SWITCH LIVE   **E** = EARTH

# TYPICAL WIRING - S PLAN, TWIN ZONE

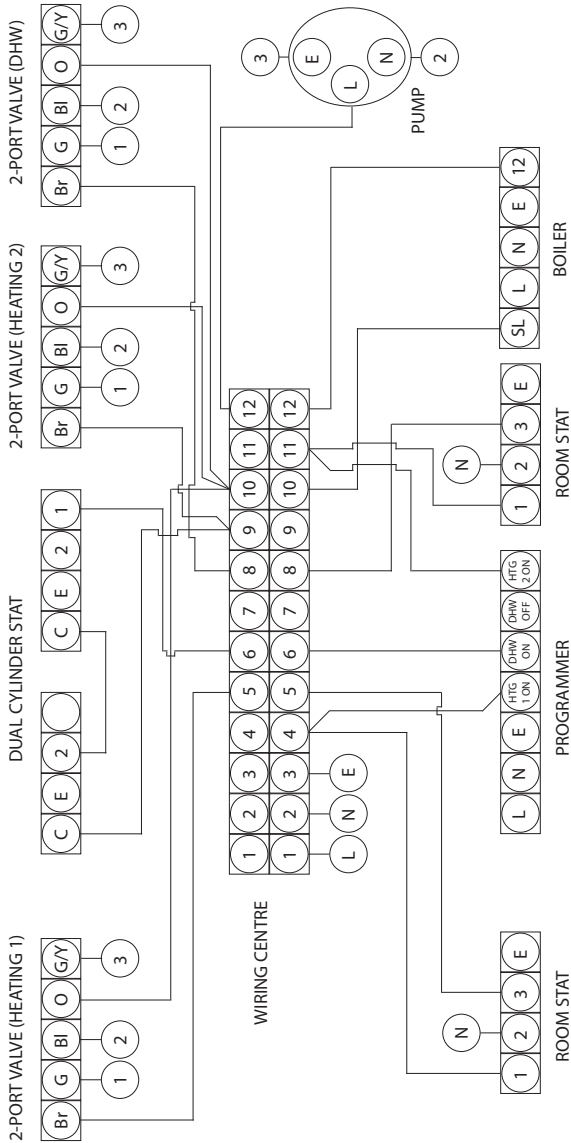

## COLOUR CODES

**W** = WHITE    **G** = GREEN    **BI** = BLUE    **G/Y** = GREEN/YELLOW    **Br** = BROWN  
**L** = LIVE    **N** = NEUTRAL    **C** = COMMON    **SL** = SWITCH LIVE    **E** = EARTH

## **COMMISSIONING - FILLING THE SYSTEM**

Check all connections for water tightness including factory made connections, as these may become loose in transit. The expansion vessel should be 3 bar (45PSI).

The hot tap furthest away from the cylinder should be opened before filling the system to purge air and flush any disturbed particles.

The pipes should be flushed before use. The remaining taps should be opened in turn to purge air from the system before turning on the electrical supply.

## **SAFETY VALVE CHECKS**

A problem is occurring if water is released from either safety valve during the heat up process (temperature relief and expansion relief.) This must be rectified before continuing. Both valves should be opened slowly one at a time, and then together, allowing as much water as possible through the tundish. Check that the discharge pipework is cleared of obstruction, free flowing, and without spillage over the tundish. Check that the valves reseal correctly when released.

## **DRAINING PROCESS**

Isolate the unit from the electric supply to prevent immersion heater burn out. Isolate the unit from the cold mains. Attach a hose to the draining tap. Ensure this reaches to a level below the unit for creating an effective siphon so that the maximum amount of water is drained from the unit. Open the hot tap closest to the unit and open the draining tap.

**Caution: Water drained off may be hot.**

## **SERVICE AND MAINTENANCE**

- **Servicing must be carried out annually by a competent installer.**
- **Any spares used must be purchased from us.**
- **Safety devices must not be bypassed. Do not use the unit if safety features are not fully operational.**
- **Proof of annual servicing is required to avoid invalidating your manufacturer's guarantee.**
- **Upon installation of the unit the installer must complete the accompanying commissioning certificate at the rear of this manual.**

## **ANNUAL SERVICING PROCESS**

This must be conducted by a competent installer on an annual basis, ideally at the same time as the annual boiler service:

1. The expansion relief valve should be eased open to allow water to flow for a minimum of 5 seconds. Close the valve and make sure it resets correctly. Repeat this procedure with the temperature & pressure relief valve. Ensure that the discharge pipework is cleared and allowing a free flow of discharge.
2. Ensure all fitted immersion heaters are working correctly. They should be controlling the water temperature between 55°C and 60°C.
3. Make sure the pressure in the expansion vessel is set to 3 bar. This is done by turning off the water supply to the unit and opening a hot tap first. Air or CO<sub>2</sub> can be used for repressuring the expansion vessel.
4. Remove the head on the inlet control set and clean the mesh filter within.
5. Update the benchmark service record supplied after every service by the installer.

## **DISCHARGE AT THE TUNDISH**

**IF WATER IS FLOWING THROUGH THE TUNDISH THIS INDICATES DISCHARGE FROM ONE OF THE SAFETY VALVES AND INDICATES A FAULT IN THE SYSTEM. CONTACT A COMPETENT PLUMBER OUT TO SERVICE OR DIAGNOSE THE SYSTEM.**

## CYLINDER FAULT FINDING

PROBLEM	POSSIBLE CAUSE	REMIADIATIVE ACTION
Water is visible at tundish	Potential discharge from T&P valve	Follow tundish/T&P fault finding
	Potential discharge from Expansion relief valve due to fault at PRV	Follow inlet control set fault finding
	Back pressure from system	Check all cold connections into mixer outlets are fed from the balanced cold service from the inlet control valve. If not, additional PRV's must be fitted.
Expansion relief valve opens when cylinder is heated	Possible fault at Expansion Vessel	Follow expansion vessel fault finding
Cylinder appears to be leaking from inside the steel case	Loose cylinder connection - notably from hot water outlet	Check all connection points including the immersion heaters and the hot outlet to ensure that these are not leaking, and remake joints if necessary.
Noise when operating tap or shower	Vibrating/insecure pipework	Ensure that all pipework is secured to the wall with pipe clips as appropriate.
Reduced water flow	Possible external water works being carried out	Check with local authorities and wait for works to be completed
	Lodged debris from mains at Inlet control set or PRV sticking	Strip & clean PRV/inline filter, or replace inlet control set.
No hot water available	Possible immersion heater failure	Follow immersion heater fault finding

## EXPANSION VESSEL FAULT FINDING

PROBLEM	POSSIBLE CAUSE	REMIADIATIVE ACTION
Discharge of water from relief valve into tundish	Expansion Vessel is undersized	Vessel needs resizing and installing by a qualified heating engineer.
	Pre-charge set incorrectly on vessel installation	Pre-charge requires setting when the system is depressurised according to manufacturer's recommendations.
	Vessel membrane is ruptured and may require replacement	Check schrader valve for leaks or damage. Replace vessel if necessary
	Membrane may be partially depressurised due to losses over time and require re-pressurisation	Check schrader valve for leaks or damage. Have heating system serviced and vessel repressurised or replaced.
Leak from flange or water connection	Failure of flange plate	Replace flange plate or entire vessel
	Ruptured membrane has led to internal corrosion and has caused leak in vessel	Replace entire vessel
Vessel appears full of liquid when system is cold	Membrane is fully depressurised	Replace membrane or entire vessel. Check schrader valve for leaks or damage.
Water discharges from vessel when schrader pin is depressed for inspection of pressure	Vessel membrane is ruptured	Replace membrane or entire vessel.

## INLET CONTROL GROUP - FAULT FINDING

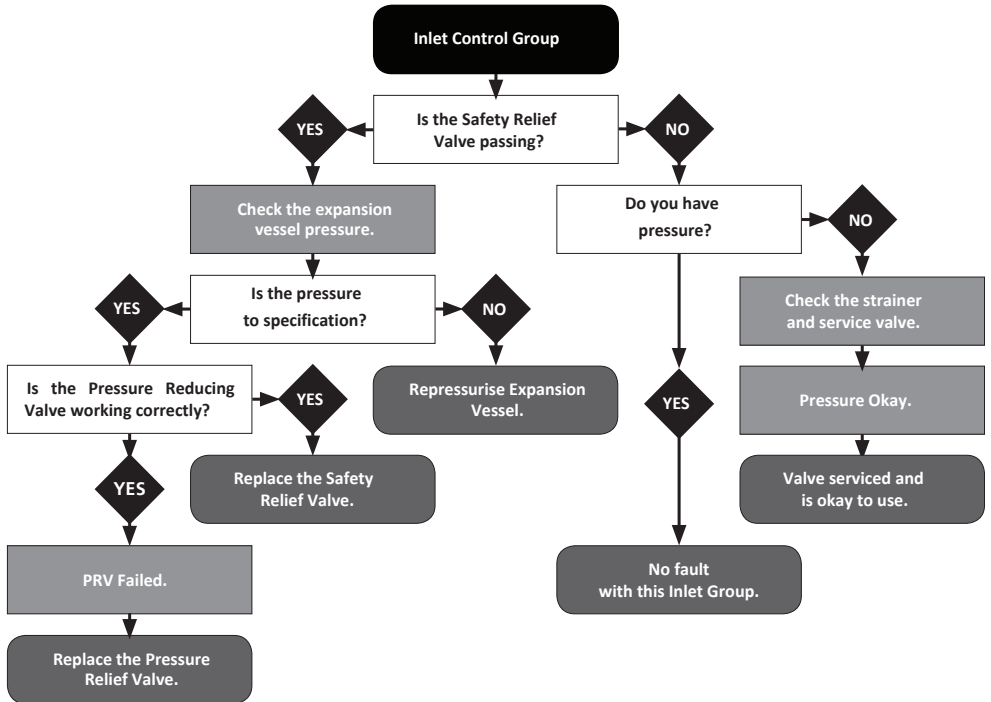

## TUNDISH - FAULT FINDING

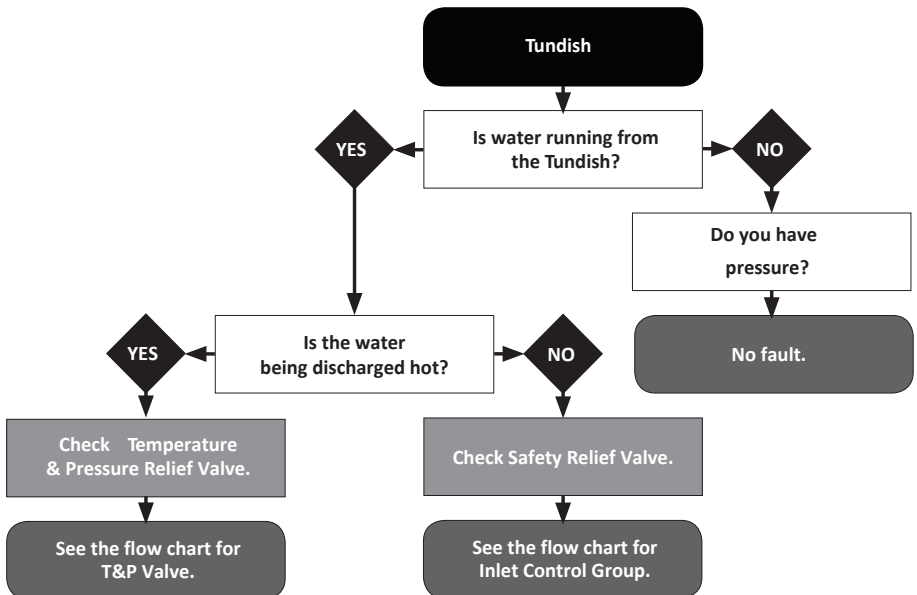

## TEMPERATURE & PRESSURE RELIEF VALVE - FAULT FINDING

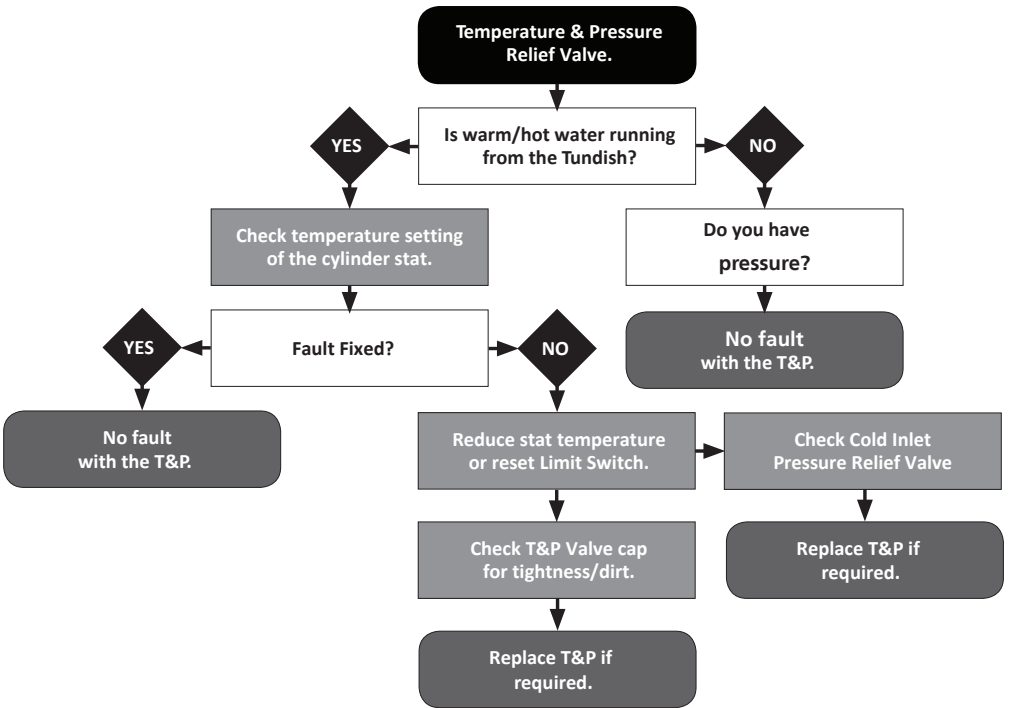

## DUAL THERMOSTAT - FAULT FINDING

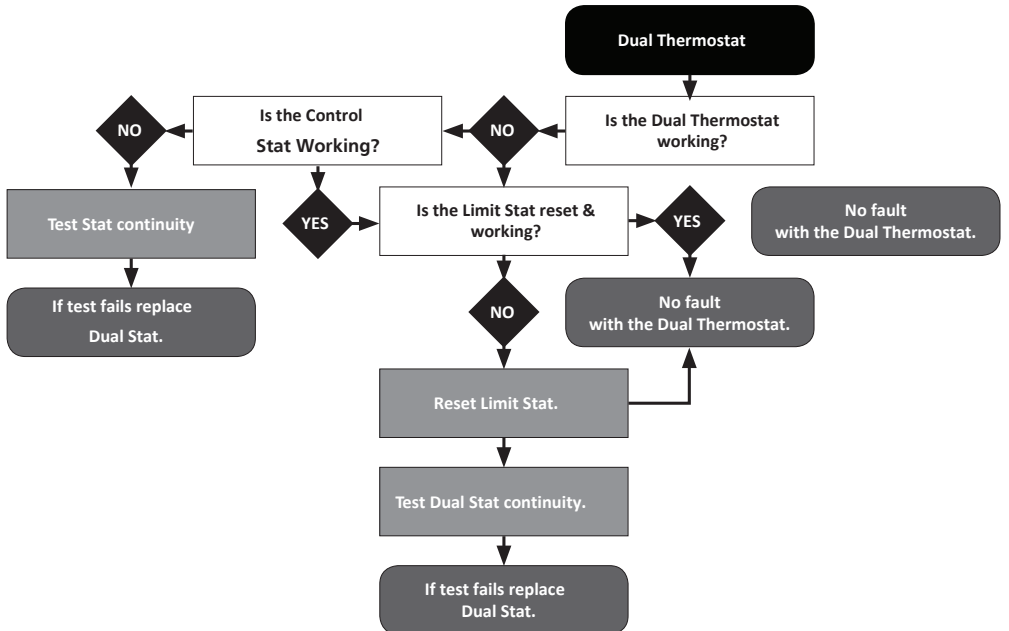

## IMMERSION HEATER - FAULT FINDING

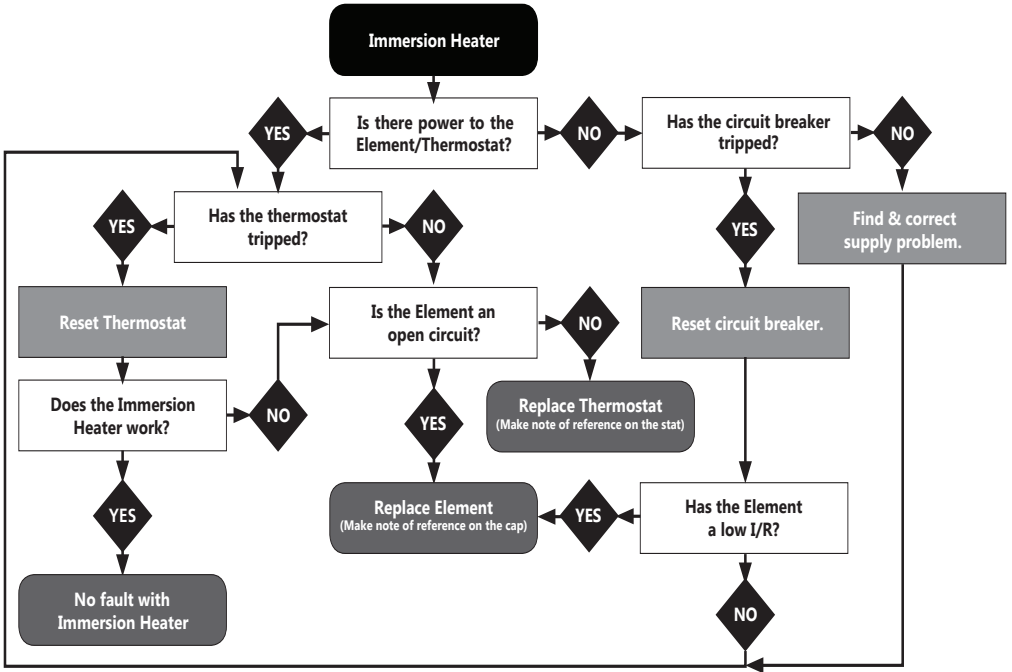

## ENERGY CUT OUT - FAULT FINDING

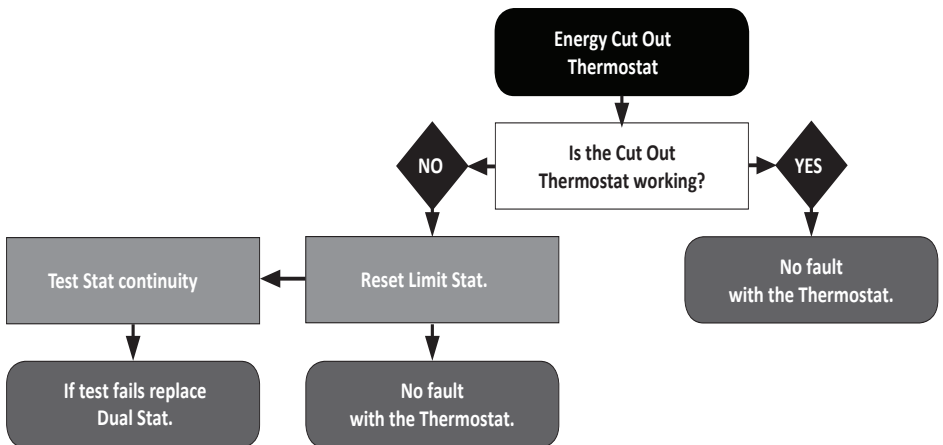

# MAINS PRESSURE HOT WATER STORAGE SYSTEM COMMISSIONING CHECKLIST

This Commissioning Checklist is to be completed in full by the competent person who commissioned the storage system as a means of demonstrating compliance with the appropriate Building Regulations and then handed to the customer to keep for future reference.

Failure to install and commission this equipment to the manufacturer's instructions may invalidate the warranty but does not affect statutory rights.

Customer name:										Telephone number:														
Address:																								
Cylinder Make and Model																								
Cylinder Serial Number																								
Commissioned by (PRINT NAME):										Registered Operative ID Number														
Company name:										Telephone number:														
Company address:																								
										Commissioning date:														
To be completed by the customer on receipt of a Building Regulations Compliance Certificate*:																								
Building Regulations Notification Number (if applicable)																								
<b>ALL SYSTEMS PRIMARY SETTINGS (indirect heating only)</b>																								
Is the primary circuit a sealed or open vented system?										Sealed					Open									
What is the maximum primary flow temperature?															°C									
<b>ALL SYSTEMS</b>																								
What is the incoming static cold water pressure at the inlet to the system?															bar									
Has a strainer been cleaned of installation debris (if fitted)?										Yes					No									
Is the installation in a hard water area (above 200ppm)?										Yes					No									
If yes, has a water scale reducer been fitted?										Yes					No									
What type of scale reducer has been fitted?																								
What is the hot water thermostat set temperature?															°C									
What is the maximum hot water flow rate at set thermostat temperature (measured at high flow outlet)?															l/min									
Time and temperature controls have been fitted in compliance with Part L of the Building Regulations?															Yes									
Type of control system (if applicable)										Y Plan					S Plan					Other				
Is the cylinder solar (or other renewable) compatible?										Yes					No									
What is the hot water temperature at the nearest outlet?															°C									
All appropriate pipes have been insulated up to 1 metre or the point where they become concealed															Yes									
<b>UNVENTED SYSTEMS ONLY</b>																								
Where is the pressure reducing valve situated (if fitted)?																								
What is the pressure reducing valve setting?															bar									
Has a combined temperature and pressure relief valve and expansion valve been fitted and discharge tested?										Yes					No									
The tundish and discharge pipework have been connected and terminated to Part G of the Building Regulations															Yes									
Are all energy sources fitted with a cut out device?										Yes					No									
Has the expansion vessel or internal air space been checked?										Yes					No									
<b>THERMAL STORES ONLY</b>																								
What store temperature is achievable?															°C									
What is the maximum hot water temperature?															°C									
<b>ALL INSTALLATIONS</b>																								
The hot water system complies with the appropriate Building Regulations															Yes									
The system has been installed and commissioned in accordance with the manufacturer's instructions															Yes									
The system controls have been demonstrated to and understood by the customer															Yes									
The manufacturer's literature, including Benchmark Checklist and Service Record, has been explained and left with the customer															Yes									
Commissioning Engineer's Signature																								
Customer's Signature																								
(To confirm satisfactory demonstration and receipt of manufacturer's literature)																								

\*All installations in England and Wales must be notified to Local Authority Building Control (LABC) either directly or through a Competent Persons Scheme. A Building Regulations Compliance Certificate will then be issued to the customer.



## SERVICE RECORD

It is recommended that your hot water system is serviced regularly and that the appropriate Service Record is completed.

### Service Provider

Before completing the appropriate Service Record below, please ensure you have carried out the service as described in the manufacturer's instructions.

<b>SERVICE 01</b>	Date:	<b>SERVICE 02</b>	Date:
Engineer name:		Engineer name:	
Company name:		Company name:	
Telephone No:		Telephone No:	
Comments:		Comments:	
.....		.....	
.....		.....	
.....		.....	
.....		.....	
Signature		Signature	
<b>SERVICE 03</b>	Date:	<b>SERVICE 04</b>	Date:
Engineer name:		Engineer name:	
Company name:		Company name:	
Telephone No:		Telephone No:	
Comments:		Comments:	
.....		.....	
.....		.....	
.....		.....	
.....		.....	
Signature		Signature	
<b>SERVICE 05</b>	Date:	<b>SERVICE 06</b>	Date:
Engineer name:		Engineer name:	
Company name:		Company name:	
Telephone No:		Telephone No:	
Comments:		Comments:	
.....		.....	
.....		.....	
.....		.....	
.....		.....	
Signature		Signature	
<b>SERVICE 07</b>	Date:	<b>SERVICE 08</b>	Date:
Engineer name:		Engineer name:	
Company name:		Company name:	
Telephone No:		Telephone No:	
Comments:		Comments:	
.....		.....	
.....		.....	
.....		.....	
.....		.....	
Signature		Signature	
<b>SERVICE 09</b>	Date:	<b>SERVICE 10</b>	Date:
Engineer name:		Engineer name:	
Company name:		Company name:	
Telephone No:		Telephone No:	
Comments:		Comments:	
.....		.....	
.....		.....	
.....		.....	
.....		.....	
Signature		Signature	

## GUARANTEE AND EXEMPTIONS

The cylinder carries a 25-year guarantee against faulty materials or manufacturing, based upon the following conditions:

- Correct installation as per this document and all relevant standards, regulations, and codes of practice in force at the time.
- The Benchmark Commissioning Checklist has been completed.
- The unit has been serviced annually.
- The product has not been modified in any way, other than by us.
- There has not been any misuse, tampering, or neglect of the cylinder.
- It has only been used for the storage of potable water.
- It has not been subjected to frost damage.
- The system is fed from a public mains water supply.
- Storage temperatures have not exceeded 65°C.
- Installations made only in the United Kingdom.
- The water chemistry used in the system is found to be above the maximum allowances.
- Units are not installed with uncontrollable heat sources (e.g. wood burning stoves).
- For commercial or heavy-duty installations where constant usage and reheating is required, titanium immersion heaters must be fitted to comply with the warranty.
- The guarantee period starts from the date of purchase.
- The extended guarantee is not transferable and rests with the original householder.

## EXCLUSIONS

- The effect of scale build-up on the unit or its components
- Any labour charges associated with replacing the unit or its parts
- Any consequential losses caused by the failure or malfunction of the unit.

Note: Invoices for servicing may be requested to prove that the unit has been serviced annually. All the components fitted to/or supplied with the cylinder carry a 2-year guarantee. The guarantee starts when the cylinder is first filled.

## CLAIMS

**On the rare occasion of a fault occurring, we will only consider sensible claims that are submitted in full at the time when the faulty part/unit is returned to us.**

**We will not cover any installer claims for excessive travelling where the installer has accepted a job more than 30 miles from their base of operations.**

**Removal costs cannot be recovered for the collection of a faulty unit from a difficult to reach area or where cylinder access has been restricted (as per this manual guidance.)**

**Claims will not be accepted for units that have not been installed in accordance with this manual.**

## PROBLEM GUIDANCE

When a problem arises, your first point of contact is the plumber who fitted the unit (in the first year), followed by the plumber who carries out the annual servicing of your unit for you.

If your cylinder begins to leak, we will supply you with a new one. To prevent fraud, we request an up-front payment in this case while we establish the cause of the fault. The original unit must be returned to us for inspection along with a copy of your service record and commissioning checklist. Your upfront payment will be refunded as soon as it is confirmed that the cylinder has failed within the terms of our warranty.

If a component part fails within the two-year guarantee, we will send you a new one with an upfront charge. Your credit card details may be required to prevent fraud. We ask you to post the faulty part back to us by recorded delivery within a month. A refund will be issued once the part has been tested and proven to be at fault.

## APPENDIX - WATER CHEMISTRY

This water heater is manufactured to suit the water conditions of most public reticulated water supplies. However, there are some known water chemistries which can have detrimental effects on the cylinder. If you are unsure of your water chemistry, you may be able to obtain the relevant water chemistry information from your local water supply authority.

\*Our warranty will not apply where water stored in the storage cylinder exceeds at any time any of the following levels: - TOTAL HARDNESS 200mg/L, TOTAL DISSOLVED SOLIDS 600mg/L

## CONDITIONS OF SALE 1. DEFINITIONS

"Buyer" means the person who acquires a quotation of the Company for the sale of the Goods or whose order for the Goods is accepted by the Company;  
"Company" means UK Cyfnders.

"Conditions" means the terms and conditions of sale set out in this document and any special terms and conditions agreed in writing by the Company and the Buyer ("Contract" means the contract for the purchase and sale of the Goods  
"Goods" means the goods which the Company is to supply and which the Buyer agrees to buy in accordance with these conditions  
"Price" means the price for the Goods including transport and insurance (if any) 1.2 In these Conditions to any provision of a statute shall be construed as a reference to that provision as amended re-enacted or extended at the relevant time 1.3 All things in these Conditions are to be construed in their ordinary meaning unless otherwise stated.

### 2. BASIS OF SALE

2.1 The Company shall sell and the Buyer shall purchase the Goods in accordance with:- 2.1.1 the Company's quotation (if provided by the Buyer) and accepted by the Buyer;

2.1.2 (if the Company does not submit a quotation following a request or purported order from the Buyer for Goods) in accordance with the Company's offer to the Buyer (if accepted by the Buyer) subject in either case to these Conditions, which shall govern the Contract to the exclusion of any other terms, special terms to which any such quotation or offer is accepted, or otherwise.

2.2 Any variation to these Conditions (including any special terms and conditions agreed between the parties) shall be incapable of being agreed in writing by the Buyer and the Company.

2.3 Any advice or recommendation given by the Company or its employees or agents to the Buyer or its employees or agents as to the storage application or use of the Goods which is not confirmed in writing by the Company is followed or acted upon unless the Buyer's own risk and accordingly the Company shall not be liable for any such advice or recommendation which is not so confirmed.

2.4 Any typographical clerical or other error or omission in any sales literature quotation price list acceptance of offer invoice or other document or information issued by the Company shall be subject to correction without any liability on the part of the Company.

2.5 All specifications, drawings, particulars of weight and dimensional and performance data contained in any of the Company's literature are approximate only. 2.5 The Company reserves the right to improve and/or modify any specifications, designs and dimensions without notice.

2.7 For the avoidance of doubt nothing in these Conditions or any Contract shall confer on any third party any benefit nor the right to enforce any term of these Conditions or any Contract whether pursuant to the Contracts (Rights of Third Parties) Act 1999.

### 3. THE PRICE AND PAYMENT

3.1 The Price shall be either:-

3.1.1 the Company's quotation price which shall only be valid for 30 days from its date after which time the Price may be altered by the Company and shall be subject to the Company requesting; or  
3.1.2 where no price has been quoted the Price listed in the current price list of the Company sent by the Company to the Buyer at the time to time.

3.2 Except as otherwise stated in the Company's quotation or in its price list of the Company or otherwise agreed in writing between the Buyer and the Company, all prices are given by the Company to include the Company's charges for transport and insurance.

3.3 The Price and any other sums payable by the Buyer to the Company is exclusive of any applicable Value Added Tax, which the Buyer shall be additionally liable to pay to the Company.

3.4 Subject to any special terms agreed in writing between the Buyer and the Company, the Company may invoice the Buyer for the Price for the Goods or for any part of the Goods, (or any instalment of the Goods) unless the Goods are to be collected by the Buyer or the Buyer wrongfully fails to take delivery of the Goods, in which event the Company shall be entitled to invoice the Buyer for the Price at any time after the Company has notified the Buyer that the Goods are ready for collection or that the case may be for the Company to deliver the Goods as well as otherwise agreed by the Buyer and

3.5 The Price and VAT shall be due within the agreed period from the date of the invoice without deduction or set off. Time for payment shall be of the essence

3.6 If the Buyer fails to make any payment on the due date then without prejudice to any other right or remedy available to the Company the Company shall be entitled to 3.6.1 cancel the contract or suspend any further deliveries to the Buyer  
3.6.2 appropriate any payment made by the Buyer to such of the Goods (or the Goods supplied under any other contract between the Buyer and the Company) as the Buyer thinks fit (notwithstanding any payment appropriation by the Buyer) and  
3.6.3 charge the Buyer interest (both before and after any judgement) on the amount unpaid at the rate of 8% per cent per annum above Barclays Bank PLC base rate from time to time until payment in full is made (a part of a month being treated as a full month for the purpose of calculating interest).

### 4. THE GOODS

4.1 The quantity and description of the Goods shall be as set out in the Company's quotation or in the Company's offer (as the case may be) and

4.1.2 the quality and specification for the Goods shall be as set out in the Company's quotation (where there is no quotation) in the Company's literature and brochure for the Goods in question.

4.2 The Buyer shall be responsible to the Company for ensuring the accuracy of the terms of any order and any information supplied to the Company by the Buyer (including but without limitation the use to which the Goods will be put and any applicable specification) submitted by the Buyer and for giving the Company any necessary information relating to the Goods within a sufficient time to enable the Company to perform the Contract in accordance with its terms. 4.3 If the Goods are to be manufactured or any product to be supplied to the Company in accordance with a specification submitted by the Buyer, the Buyer shall indemnify the Company against all losses damages costs, claims, demands, liabilities and expenses awarded against or incurred by the Company in connection with and/or paid or agreed to be paid by the Company in settlement of any claim or in respect of any patent copyright design trade mark or industrial or intellectual property rights of any other person which results from the Company's use of the Buyer's specification or

from compliance by the Company with the Buyer's instructions whether express or implied.

4.3.1 Any order which has been accepted by the Company may be cancelled by the Buyer as except with the agreement in writing of the Company and on terms that any deposit paid shall not be repayable and that the Buyer shall indemnify the Company in full against all (including loss of profits costs (including the cost of all labour and materials used) damages charges and expenses) incurred by the Company in connection with the order and in respect of any patent copyright design trade mark or industrial or intellectual property rights of any other person which results from the Company's use of the Buyer's specification or

4.5 All designs, sketches, or similar articles supplied by or submitted in confidence by the Company shall remain the property of the Company and may not be disclosed by or used by nor copied or otherwise reproduced by the Buyer without the prior written consent of the Company.

### 5. DELIVERY OF GOODS

5.1 Unless otherwise agreed in writing the Company shall deliver the Goods to such delivery address as is specified by the Buyer to the Company at such time as the Goods or part thereof (as the case may be) are ready for delivery.

5.2 The Buyer shall be responsible for ensuring that the Goods at the delivery address shall arrive the Company of any local or internal laws, byelaws or rules relating to parking or loading of vehicles at the delivery address.

5.3 The Buyer shall be responsible for ensuring that access to the delivery address is wholly by a road with a surface capable of withstanding the weight of the vehicle carrying the Goods.

5.4 Any dates quoted for delivery of the Goods are approximate only and the Company shall not be liable for any delay in delivery of the Goods; however caused Time for delivery shall not be of the essence unless previously agreed by the Company in writing. The Goods may be delivered by the Company in advance of the Delivery Date upon giving reasonable notice to the Buyer

5.5 Where the Goods are to be delivered in instalments each delivery shall constitute a separate contract and failure by the Company to deliver any one or more of the instalments in accordance with these Conditions or any claim by the Buyer in respect of any one or more instalments shall not entitle the Buyer to treat the Contract as a whole as repudiated

5.6 If the Buyer fails for any reason whatsoever to take delivery of the Goods or fails to give the Company adequate delivery instructions at the time stated for delivery (whether or not by reason any cause beyond the Buyer's reasonable control) or by reason of the Company's fault) then without prejudice to any other right or remedy available to the Company the Company may:

5.6.1 store the Goods until actual delivery and charge the Buyer for the reasonable costs (including insurance) of returning the Goods to the Company's premises; and

5.6.2 sell the Goods at the best price readily obtainable and (after deducting all reasonable storage and selling expenses) account to the Buyer for the excess over the Price or charge the Buyer for any shortfall below the Price.

5.8 Goods may not be returned to the Company except by prior written permission of an authorised officer of the Company and such return shall be subject to payment by the Buyer of handling and re-stocking charges, transport and all other costs incurred by the Company.

### 6. RISK AND RETENTION OF TITLE

6.1 Risk shall pass to the Buyer as from the Buyer's risk immediately upon delivery to the Buyer or into custody on the Buyer's behalf to the Buyer's Order. The Buyer shall effect adequate insurance of the goods against all risks to the full invoice value of the goods, such insurance to be effective from the time of delivery until payment of the goods shall pass to the Buyer as the Company provided.

6.2 Property in the goods supplied hereunder will pass to the Buyer when full payment has been made by the Buyer to the Company for:-

6.2.1 all the goods of the subject of this contract.

6.2.2 all other goods of the subject of any other contract between the Buyer and the Company, which, at the time of payment of the full price of the goods sold under this contract, have been delivered to the Buyer but not paid for in full. 6.3 until property in the goods is supplied hereunder to the Buyer in accordance with the terms of the Contract.

6.3 The Buyer shall hold the goods in a fiduciary capacity for and shall store them separately from any other goods in the Buyer's possession and in a manner which enables them to be identified as our goods.

6.4 The Buyer shall immediately return the title to the Company should the Company's authorised representative so request. All the necessary incidents attending such a fiduciary relationship shall apply.

6.4.1 The Buyer's right to possess the goods shall cease forthwith upon the happening of any of the following events, namely:-  
6.4.1.1 if the Buyer fails to make payment in full for the goods within the time stipulated in clause 3 hereof.

6.4.1.2 if the Buyer, not being a company, commits any act of bankruptcy, makes any proposal to his creditors for a compromise or does anything which would entitle a petition for a Bankruptcy Order to be presented.

6.4.1.3 if the Buyer, being a company, does anything or fails to do anything which would entitle an administrator or an administrator or a receiver or a liquidator to be appointed or to take any action which would entitle any person to present a petition for winding up or to apply for an administration order.

6.5 The Buyer hereby grants to the Company an irrevocable licence to enter at any time any vehicle or premises owned or occupied by the Buyer or in the possession or control of the Buyer for the purposes of repossessing the goods which are the subject of this contract which has remained in the Company's possession under paragraph 2 (b) above. The Company shall not be responsible for and the Buyer will indemnify the Company against liability in respect of damage caused to any vehicle or premises in such repossession and removal and the goods which are the subject of this contract, and the Company shall be liable to the Buyer for any such damage.

6.6 notwithstanding paragraph 4 (b) hereof, the Buyer shall be permitted to sell the goods to third parties in the normal course of business. In this respect the Buyer shall act in the capacity of the Companies commission agent and the proceeds of such sale:

6.6.1 shall be held in trust for us in a manner which enables such proceeds to be identified as such; and

6.6.2 shall not be mixed with other monies nor paid into an overdraft bank account. The Company, as principal, shall remunerate the Buyer as commission agent a commission depending upon the surplus which the Buyer can obtain over and above the sum, stipulated in the Contract of contract supply which will satisfy the Company.

6.7 In the event that the Buyer shall sell any of the goods pursuant to clause 5 (b) hereof, the Buyer shall forthwith inform the Company of the Buyer's Contract and add to the contract the terms and conditions of sale set out in clause 6.8. Below the property in the goods passes to the Buyer under paragraph 3 (a) above the goods are to become free of any land or building owned by the Buyer if he hereby agreed and declared that such affixation shall not have the effect of passing property in the goods to the Buyer. Furthermore, if before property in the goods shall pass to the Buyer under paragraph 3 (b) hereof, the goods are or become affixed to any land or building owned by the Buyer, the Buyer shall:-

6.8.1 ensure that the goods are capable of being removed without material injury to such land or building;

6.8.2 take all necessary steps to prevent title to the goods from passing to the landlord of such land or building;

6.8.3 forthwith inform the Company in writing of such affixation and of the address of the land or building concerned. The Buyer warrants to repair and make good any damage caused by the affixation of the goods to their removal from any land or building and to indemnify the Company in respect of any liability the Company may incur or sustain as a result of affixation or removal. 6.9 In the event, damage or before property in the goods has passed to the Buyer under paragraph 3 (b) hereof, the goods or any of them are lost, stolen, damaged or destroyed:-

6.9.1 the Buyer shall forthwith inform the Company in writing of the fact and circumstances of such loss, theft, damage or destruction.

6.9.2 The Buyer shall assign to the Company the benefit of any insurance claim in respect of the goods so lost, stolen, damaged or destroyed.

7. WARRANTIES AND LIABILITY 7.1 The Company warrants that it is a member of the UK Cyfnders 7.1.1. Subject to the following provisions, the Company warrants that the Goods will be free from defects in material and workmanship for a period of 24 months from the delivery to the Buyer, unless a period of different duration is specified in the product installation instructions in respect of that product and/or its specific warranty terms, or specified components thereof.

7.2 The warranty in clause 7.1 is given by the Company subject to the following conditions:

7.2.1 The Company shall be under no liability in respect of any defect in the Goods arising from any information drawing design or specification supplied to the Company.

7.2.2 The Company shall be under no liability in respect of any defect arising from fire and wear and tear of the Goods, abnormal working conditions failure to follow the Company's instructions (whether oral or in writing) misuse or alteration or repair of the Goods, whether or not caused by any consequential damage(s) occurred to the Buyer, or the Buyer's customer's property, caused by failure of the Company's Goods. Any such costs incurred shall be claimed by the Buyer as the Buyer's customer's property.

7.2.4 The above warranty does not extend to parts, materials equipment not manufactured by the Company in respect of which the Buyer shall only be entitled to the benefit of any such warranty or guarantee as is given by the manufacturer to the Company. 7.2.5 The above warranty shall not apply to any goods which are represented or sold by the Company as being of a different type other than in the terms made or given by the Company to the Buyer in these Conditions nor shall the Buyer have any authority to commit the Company to provide any service in relation to the Goods. The Buyer shall indemnify the Company against all losses, damages, costs, claims, demands, liabilities and expenses incurred or suffered by the Company in respect of or arising out of any such statement, representation or warranty made or given by the Buyer in contravention of this clause.

7.3 The Company's liability to the Buyer for:-

7.4.1 death or injury resulting from its own fault or that of its employees' agents' or subcontractors' negligence; and

7.4.2 damage suffered by the Buyer as a result of any breach of the obligations implied by Section 12 of the Sale of Goods Act 1979 shall not be limited

7.5 Subject as expressly provided in these Conditions all other warranties conditions or terms whether implied by statute or otherwise in law or otherwise are hereby excluded

7.6 If the Company fails to deliver the Goods for any reason other than any cause beyond the Company's reasonable control or if the Buyer fails then to take delivery of the Goods, the Company shall only be liable to the Buyer for and the Company's liability shall be limited to the excess (if any) of the cost to the Buyer (in the cheapest available material) of similar goods to replace those not delivered over the Price of the Goods.

7.7 The Buyer shall examine all Goods delivered forthwith following delivery. Any claim by the Buyer which is based on any defect in the quality or condition of the Goods or their failure to correspond with specification shall (whether or not delivery is refused by the Buyer) be notified to the Company within 7 days from the date of delivery or (where the defect or failure was not apparent upon reasonable inspection) within a reasonable time after discovery of the defect or failure if the defect or failure is not obvious and the Buyer does not notify the Company accordingly the Buyer shall not be entitled to reject the Goods and the Company shall have no liability for such defect or failure and the Buyer shall be bound to pay the Price as if the Goods had been delivered in accordance with the Contract in full. 7.8 The Buyer shall be entitled to reject the Goods if the Goods do not conform to the specification or if it would be unreasonable for the Buyer to reject them 7.9 The Company shall be entitled to examine any Goods which are the subject of any claim by the Buyer and to remove such Goods or any part thereof for testing. No tests carried out by the Buyer will be binding on the Company unless carried out strictly in accordance with a method previously agreed by the Company and approved by the Buyer as a suitable for the purpose.

7.9.9 Where any valid claim in respect of any of the Goods which is based on any defect in the quality or condition of the Goods or their failure to meet specification is notified to the Company in accordance with these Conditions the Company shall be entitled to inspect the Goods and to reject the Goods (or any part thereof) if the Company's sole discretion is to refund to the Buyer the Price (or a proportionate part of the Price) but the Company shall have no further liability to the Buyer.

7.10 Where failed Goods are returned to the Company and subsequently found to have no fault found or failed due to reasons outside the control of the Company, the Company reserves the right to claim any subsequent entitlement from the Buyer.

7.11 Without prejudice to the provisions of clauses 7.5, 7.6, 7.7, 7.9 and 7.10 the entire liability of the Buyer under or in connection with the Contract shall not exceed the Price of the Goods.

7.12 The Company shall not be liable to the Buyer or be deemed to be in breach of the Contract by reason of any delay in performing any or failure to perform any of the Company's obligations in relation to the Goods if the delay or failure was due to any cause beyond the Company's reasonable control (without limiting the foregoing, the following shall be regarded as causes beyond the Company's reasonable control: fire, explosion, flood, pest, war, strike, riot, civil disturbance, or inclusion of any of the following:-

7.12.1 war or threat of war, sabotage, insurrection, civil disturbance or requisition; 7.12.2 acts, restrictions, regulations, by-laws, prohibitions or measures of any kind on the part of any Governmental, Parliamentary or Local Authority;

7.12.3 imports or export restrictions or trade embargos;

7.12.4 strikes, lockouts or other industrial or trade disputes (whether employees of the Company or of a third party);

7.12.5 difficulties in obtaining raw materials, labour, fuel or machinery; 7.12.7 power failure, failure of tele-communications lines, failure or breakdown of plant, machinery or vehicles;

7.12.8 fire or malicious damage;

7.12.9 defaults for any reason whatsoever of suppliers or sub-contractors of the Company.

7.12.10 incompleteness or inaccuracy of any technical information which it is the responsibility of the Buyer to provide in connection with the Contract.

8.1 This clause applies if:

8.1.1 the Buyer makes any composition or voluntary arrangement with its creditors (being an individual or firm) becomes bankrupt or (being a company) becomes subject to an administration order or seeks an out of court route into administration or goes into liquidation (otherwise than for the purposes of amalgamation or reconstruction) or a moratorium comes into force in respect of the Buyer (within the meaning of the Insolvency Act 1986); or

8.1.2 an encumbrance takes possession or a receiver or manager or administrative receiver or administrator is appointed of any of the property or assets of the Buyer; or 8.1.3 the Buyer ceases or threatens to cease to carry on business or

8.1.4 the Company reasonably apprehends that any of the events mentioned above is about to occur in relation to the Buyer and notifies the Buyer accordingly as a result of this clause applying then without prejudice to any other right or remedy available to the Company the Company shall be entitled to stop any Goods in transit, cancel the Contract or suspend any further deliveries under the Contract without any liability to the Buyer and if the Goods have been delivered but not paid for the Price shall become the property of the Company and the Buyer shall be bound to pay the Price to the Company.

9. HEALTH AND SAFETY INFORMATION The Buyer agrees and undertakes with the Company to ensure that the provisions of all instruction manuals including health and safety instructions and any other information or document relating to the use of the Goods provided by the Company with the Goods are fully read and understood as to ensure so far as is reasonably practicable that the Goods will be safe and without risk to health at all times, when it is being installed, used, cleaned or maintained by a person at work and that all such manuals instructions or documents remain with the Goods.

10. GENERAL 10.1 The Contract is personal to the Buyer which may not assign or dispose of any of its rights or obligations or otherwise delegate any of its obligations under the Contract without the written consent of the Company.

10.2 The Company shall not be bound by the terms, conditions and obligations under the Contract and to such contract or otherwise delegate any of its obligations under the Contract.

10.3 Any notice required or permitted to be given by either party to the other under these Conditions shall be in writing including facsimile and shall be deemed to have been received if it is registered office or principal place of business or other address as may at the relevant time have been notified pursuant to this provision to the party giving the notice and shall be deemed to have been received by the party to whom it was addressed, if sent by facsimile upon its transmission if during a normal business day and otherwise if during a normal business day: 22 hours a day, 7 days a week.

10.4 No waiver by the Company of any breach of the Contract by the Buyer shall be considered as a waiver of any subsequent breach of the same or any other provision 10.5 In any provision of these Conditions is held by a Court or other competent authority to be invalid or unenforceable in whole or in part the validity of the other provisions of these Conditions and the remainder of the provisions in question shall not be affected thereby.

10.6 The terms and these Conditions shall be governed by the laws of England 10.7 The parties hereby submit to the non-exclusive jurisdiction of the English courts 10.8 The Buyer shall indemnify the Company for all costs and damages, including attorneys' fees, suffered by the Company as a result of the Buyer's actual or threatened breach of these terms and conditions.

11. INFORMATION The Company will provide the Buyer with information as to the proper and safe use of the Goods and the Buyer shall at all times check and understand the terms and conditions of any other information relating to the use of the Goods. Specific product warranty terms are available on request.

Terms & Conditions may change without prior notice being given, for up to date terms please visit [www.ukcyfnders.co.uk](http://www.ukcyfnders.co.uk)

**UK Cylinders Limited**

Unit 3, RCM Business Centre, Sandbeds Trading Estate, Dewsbury Rd, Ossett, WF5 9ND

Tel: **03330 329650** Email: **[sales@ukcylinders.co.uk](mailto:sales@ukcylinders.co.uk)**