

# UK CYLINDERS

YOUR HOT WATER SPECIALISTS



## HEAT PUMP PRE-PLUMB ADDENDUM Installation Manual January 2026

### Important

This range of unvented water storage cylinders should only be installed as per these instructions by a competent and certified heating installer. By installing this product, you agree to be bound by the purchasing and warranty terms and conditions found in this manual and on our website.

### Safe Disposal and WEEE Declaration

This cylinder is manufactured and supplied with a variety of components made from recyclable materials. At the end of its working life, a hot water cylinder should be disposed of at a local Authority Recycling Centre.

The Waste Electrical and Electronic Equipment (WEEE) directive makes use of the wheelie bin symbol, which indicates that this product must not be disposed of with regular household waste. Instead, all products with this symbol must be disposed of any a designated point for the recycling of waste electrical equipment.

For more information about where you can drop off your WEEE please contact your house hold waste disposal service or the point of purchase for any of your electrical goods.



## Contents

1. Introduction	1
2. Schematic: UK Cylinders Pre-Plumbed Heat Pump Indirect Cylinder	2
3. Schematic: UK Cylinders Pre-Plumbed Combined Heat Pump Indirect Cylinder and Buffer	3
4. Installer On-site Wiring Diagram: 3-Wire 3-Port Full Diverting Valve	4
5. Component Listing	5
6. Potable (Secondary) Water Connections	5
7. System filling and Commissioning	6

### 1. Introduction

These supplementary instructions are intended to be read alongside the main product installation manual. Installers must pay close attention to all applicable legislative requirements, including Building Regulations, Water Regulations, IEE Wiring Regulations, and recognized industry best practices.

Installation must only be carried out by a qualified individual holding G3 certification or registered under a recognized Competent Person Scheme.

This guide confirms the factory pre-plumbed and pre-wired components and their configuration. It also includes a basic wiring diagram to assist with the on-site connection of room thermostats.

## 2. Schematic: UK Cylinders Pre-Plumbed Heat Pump Indirect Cylinder

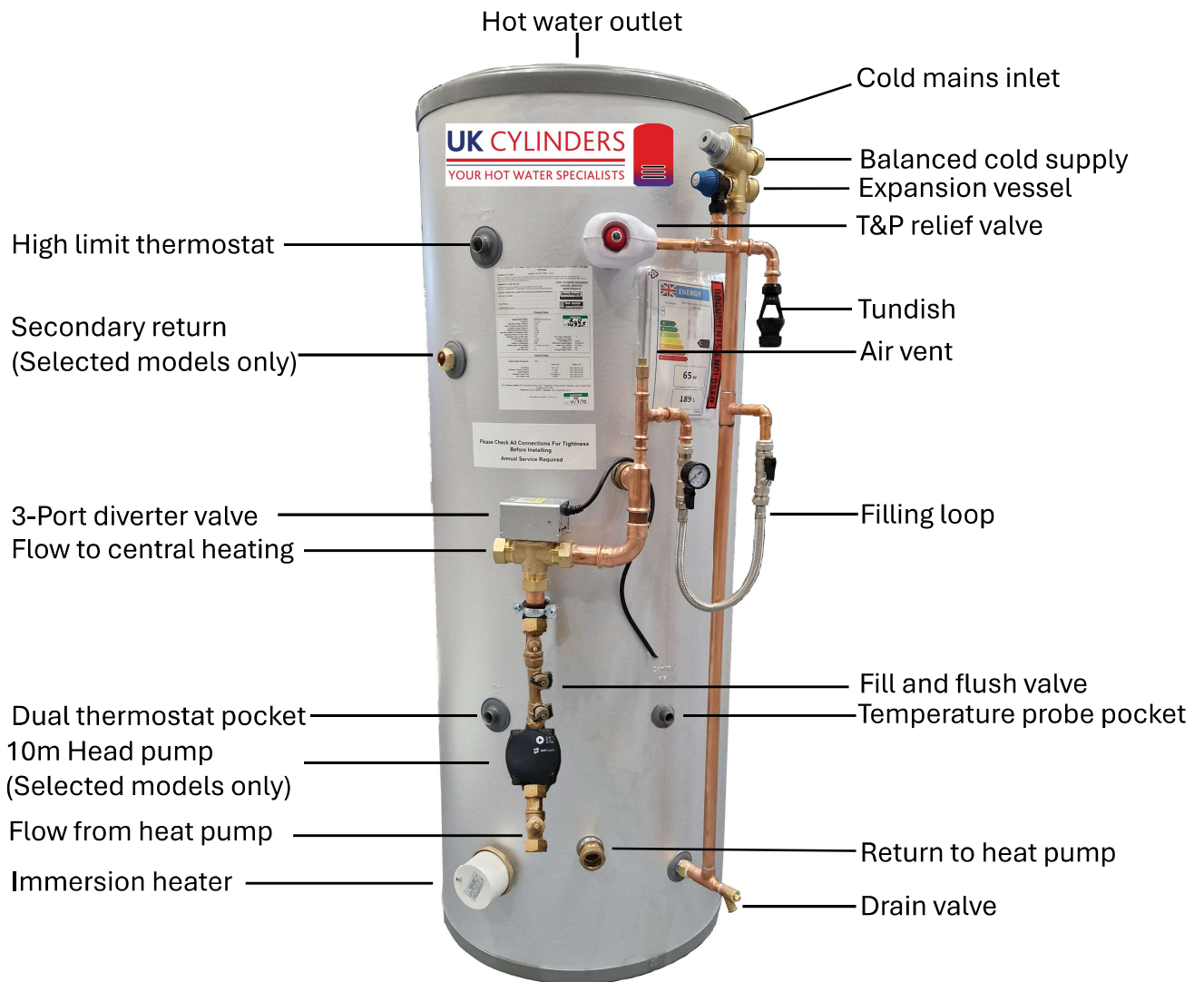

The cylinder features 1" BSP female connections for the cylinder coil on both standard diameter and Lowboy models. Slimline models utilize 22mm compression fittings. All primary water components are supplied with 28mm compression connections.

- Flow from heat pump to system:- The pipework flows into the pre-plumb cylinder pipework connecting directly to the 28mm connection on the bottom of the fill and flush device (non-pump models), or to the 10m head pump (with pump models).
- Return to heat pump:- The return connection from the cylinder coil is 1" BSPF and requires piping directly back to the heat pump. This pipework will common with the space heating return.
- Flow to central heating:- From the 3-port motorized valve, connect the space heating flow into the radiator circuit for the required heating zone(s).
- Any expansion vessel must be mounted within the warm envelope of the building and be in a position that all parts of the primary pipework can expand into it.

### 3. Schematic: UK Cylinders Pre-Plumbed Combined Heat Pump Indirect Cylinder and Buffer

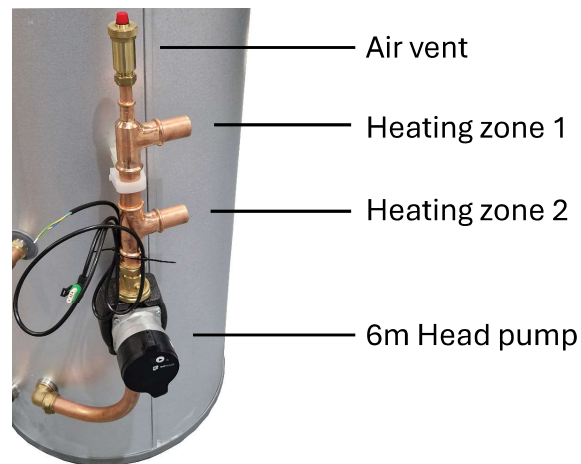
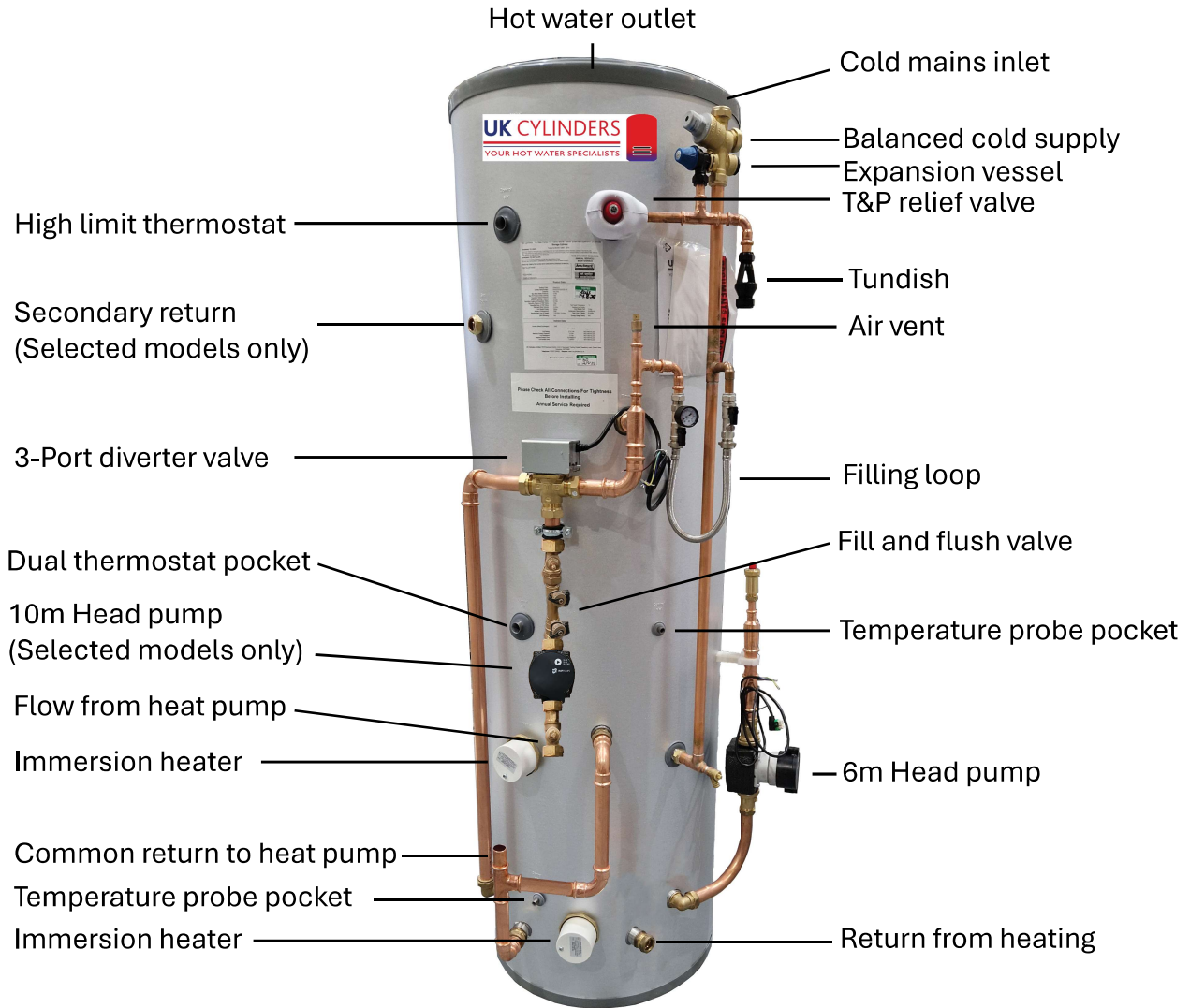

The cylinder features 1" BSP female connections for both the cylinder coil and buffer connections on standard diameter and Lowboy models. Slimline buffer models connections utilize 22mm compression fittings. All primary water components are supplied with 28mm compression connections.

- Flow from heat pump to system:- The pipework flows into the pre-plumb cylinder pipework connecting directly to the 28mm connection on the bottom of the fill and flush device (non-pump models), or to the 10m head pump (with pump models).
- Return to heat pump:- The pre-connected common return from buffer, and from cylinder coil requires piping directly back to the heat pump.
- Flow to central heating:- Connect the 28mm pipe branches from 6m head pump, emerging from the far right buffer connection, into the relevant heating zones. This may be a single zone or twin zone system.
- Central heating return:- Pipe into remaining open 1" BSPF buffer connection.
- Primary expansion:- The assembly is usually installed in the return pipework adjacent to the Heat pump appliance - see both the Heat pump manufacturer's requirements and the instructions provided with the components supplied. Installer should check whether a primary expansion vessel is required with the system, or whether this is incorporated elsewhere in the system. Check the vessel is charged to 1.5 bar on installation. Ensure the discharge pipe terminates at a point where the discharge of hot water is visible, yet does not cause any danger to people or to property. Any expansion vessel must be mounted within the warm envelope of the building and be in a position that all parts of the primary pipework can expand into it.

#### 4. Installer On-Site Wiring Diagram: 3-Wire 3-Port Full Diverting Valve

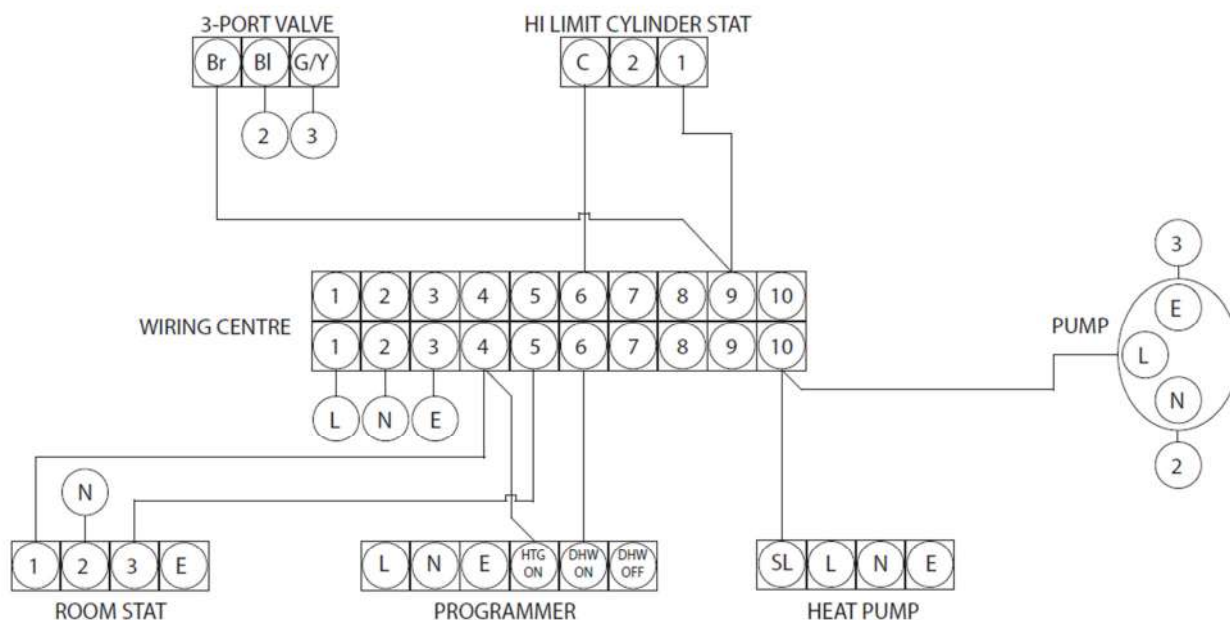

W = WHITE G = GREEN Bl = BLUE G/Y = GREEN/YELLOW Br = BROWN

L = LIVE N = NEUTRAL C = COMMON SL = SWITCH LIVE E = EARTH

## 5. Component Listing

This pre-plumbed cylinder is a standard unvented hot water storage cylinder with central heating components assembled and mounted onto the front of the casing.

In addition to the G3 safety components supplied with a standard unvented cylinder, the following components are also supplied with a pre-plumbed cylinder:

- 28mm Three port motorized diverter valve
- High limit cut-out thermostat
- Automatic air vent
- Sealed system filling loop with pressure gauge
- 28mm Fill and Flush valve
- (“With pump” models only) 10m Head pump
- (Buffer Combi models only) 6m Head pump
- (Buffer Combi models only) Primary expansion vessel & Robo kit

## 6. Potable (Secondary) Water Connections

The potable water connections are 22mm compression on the cylinder and expansion vessel, and are connected in the same manner as listed in the main installation manual. These connections include:

- Cold mains to inlet control set
- Balanced cold supply from inlet control set
- Hot water outlet
- Secondary return connection (where fitted)
- Expansion vessel
- Tundish discharge outlet

Please check all connections for tightness before installing.

## 7. System filling & Commissioning

Once all plumbing and wiring is complete, the primary system may be filled and flushed in the proprietary manner. During filling ensure all plumbing connections, including factory made connections are water tight, prior to leaving site. The effects of transit may cause some connections to subsequently leak upon filling, for which we can accept no responsibility for damage or inconvenience caused. Also, ensure all drain points and air valves etc. are fully closed. Fill via the filling loop provided, ensuring any 2 port valves and the circulating pump isolation valves are fully open.

Release all air from the pre-installed air vent installed at the highest point of the pre-plumb pipework and also any other high points in the system. The normal fill pressure is 1.0 bar to 1.5 bar - check both the heat pump and radiator manufacturers' requirements.

Once the system is full of water and devoid of air, turn on the heat pump appliance and thermostats and heat both the hot water and the heating circuits. The desired hot water temperature should be set using the heat pump user interface and should be in accordance with the homeowners requirements and the heat pump manufacturers guidelines. Check all components are functioning correctly and that there are no leaks present.

UK Cylinders

Unit 3, RCM Business Centre, Dewsbury road, Ossett, WF5 9ND

Telephone: 03330 329 650

Sales: [sales@ukcylinders.co.uk](mailto:sales@ukcylinders.co.uk)

Customer care: [customercare@ukcylinders.co.uk](mailto:customercare@ukcylinders.co.uk)